

2-channel speed sensor

Compact sensor with
HTL or TTL output signals

GEL 248

Technical information

Version 2021-01

Description

- Application-proven speed sensor based on magnetic scanning
- Suitable for the safe acquisition of creeping movements without loss of pulses as well as the acquisition of fast rotational movements
- Contactlessly scans measuring scales made of ferromagnetic materials
- Detection of direction by means of the evaluation of two channels with 90° phase offset
- Robust, compact housing for usage in harsh applications with little space
- Appropriate for tooth wheels, toothed racks, slotted discs and sprockets

Features

- For module 1.00 to 4.00 ⁽¹⁾; others upon request
- Measuring range HTL 0 Hz to 20 kHz
- Measuring range TTL 0 Hz to 20 kHz
- Temperature range -40 °C to +120 °C
- Degree of protection IP 68

Advantages

- Maintenance and wear-free operation due to contactless measurement of rotational movements
- Straightforward flange mounting

Field of application

- Rotational speed and position measurement on gears, machines and motors
- Fluid technology
 - Use in hydraulic pumps
 - Use in hydraulic motors

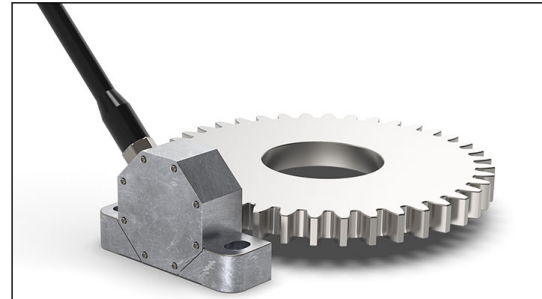

Cable outlet radial with screw sleeve

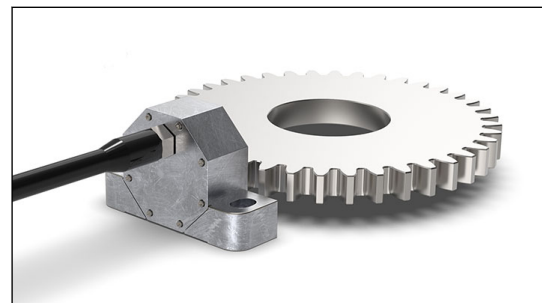

Cable outlet lateral with screw sleeve

⁽¹⁾ For the module of the standard versions, see type code

Right to technical changes and errors reserved.

Technical data

Signal pattern	V	X	T
Electrical data			
Supply voltage U_B (polarity reversal protected)	10 to 30 V DC		5 V \pm 10 %
Current consumption per channel I_B (without load)	\leq 50 mA		
Output signal (short-circuit-proof)	Square-wave signals		
Output level	HTL		TTL
Output signal level High ⁽¹⁾	$\geq U_B - 2$ V		≥ 3.5 V
Output signal level Low ⁽²⁾	≤ 1.5 V		≤ 0.8 V
Output current per channel	≤ 20 mA		
Frequency range	0 Hz to 20 kHz		
Duty ⁽³⁾	50 % \pm 10 %		
Phase offset	typ. 90°		
Dielectric strength	720 V DC; as per DIN EN 60439-1		
Requirements on the target wheel			
Module m target wheel	1.00 to 4.00 ⁽⁴⁾ ; others upon request		
Air gap permitted ⁽⁵⁾	0.2 to 2.8 mm		
Tooth shape target wheel	Involute gear teeth according to DIN 867		
Material target wheel	Ferromagnetic steel		
Width target wheel	≥ 10 mm		
Permissible eccentricity	≤ 0.3 mm	–	
Mechanical data			
Degree of protection	IP 68		
Vibration resistance	200 m/s ² (EN 60068-2-6)		
Shock resistance	2000 m/s ² (EN 60068-2-27)		
Type test	According to DIN EN 50155 possible		
Housing material, sensor	Zinc		
Weight, sensor (2 m cable)	Approx. 150 g		
Environmental conditions			
Working and operating temperature	-40 °C to +120 °C		
Storage temperature	-40 °C to +120 °C		
MTTF figure	> 2,000,000 h at 55 °C		
Electromagnetic compatibility Electromagnetic emissions Electromagnetic immunity	DIN EN 61000-6-4; DIN EN 61000-6-3 DIN EN 61000-6-2; DIN EN 61000-6-1		
Electrical connection			
Connection	Flying lead		
Screen connection	Screen connected at encoder end		
Cable outlet	Radial or lateral		
Cable length	≤ 100 m		

(1) Output signal level dependent on the output current and the temperature

(2) Depending on the output current and the temperature

(3) Depending on target wheel and air gap

(4) For the module of the standard versions, see type code

(5) Depending on signal pattern and target wheel module. Pay attention to air gap table in this document.

Output signals, core assignment, cable data

Signal pattern

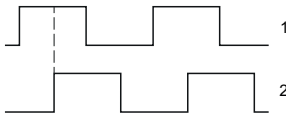
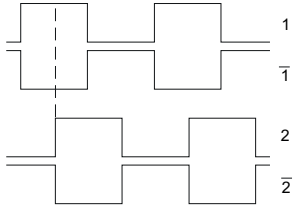
Output signals		Supply voltage	Pulse diagram
V	2 channels, 90° phase offset	10 to 30 V DC	
X	2 channels, 90° phase offset, with inverse signals	10 to 30 V DC	
T	2 channels, 90° phase offset, with inverse signals	5 V ± 10 %	

Output signal level

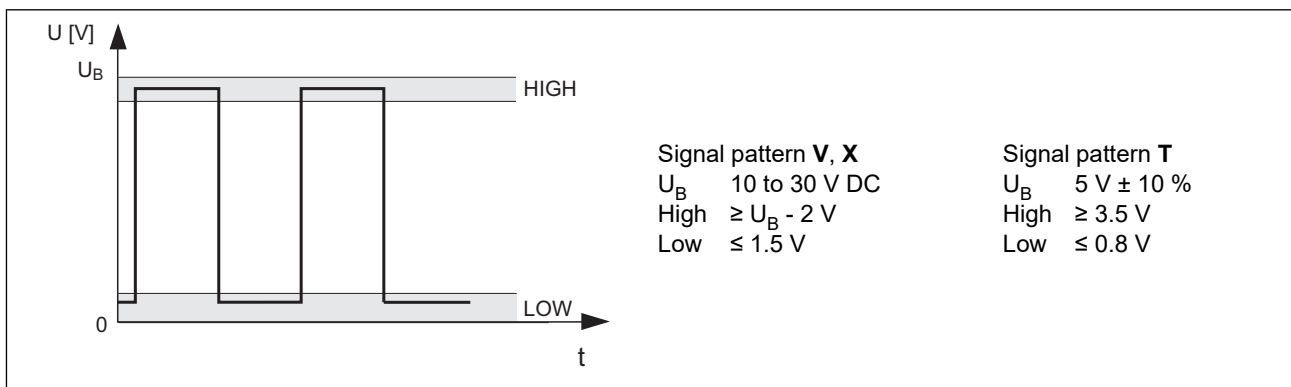

Core assignment

Signal	V	X	T
Channel 1	yellow	yellow	yellow
Channel 2	white	white	white
Channel $\bar{1}$		black	black
Channel $\bar{2}$		brown	brown
GND (0 V)	blue	blue	blue
+ U_B	red	red	red

Flying lead / Screen connected at encoder end

Cable data

Signal pattern	V	X	T
Cable	halogenfree and screened ⁽¹⁾	halogenfree and screened ⁽¹⁾	halogenfree and screened ⁽¹⁾
Cable diameter (D_C)	5.5 ± 0.2 mm	5 - 0.3 mm	5 - 0.3 mm
Cable cross section	4 × 0.25 mm ²	9 × 0.15 mm ²	9 × 0.15 mm ²
Min. bending radius static / dynamic (R_C)	11 mm / 28 mm	10 mm / 25 mm	10 mm / 25 mm

⁽¹⁾ specification upon request

Technical drawings

Dimensional drawings

Cable outlet A
(Cable outlet radial with screw sleeve)

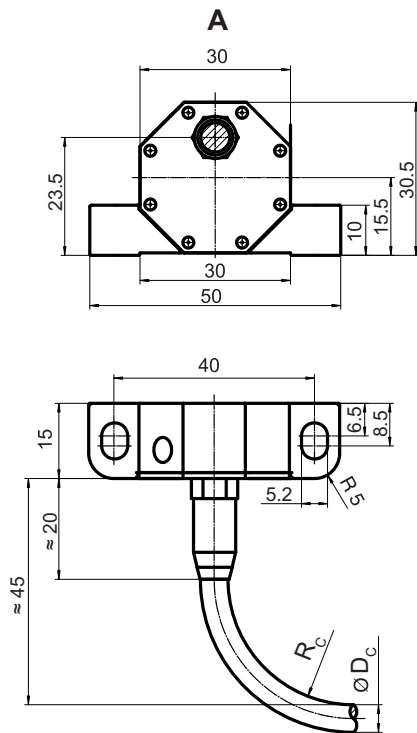

Cable outlet B
(Cable outlet lateral with screw sleeve)

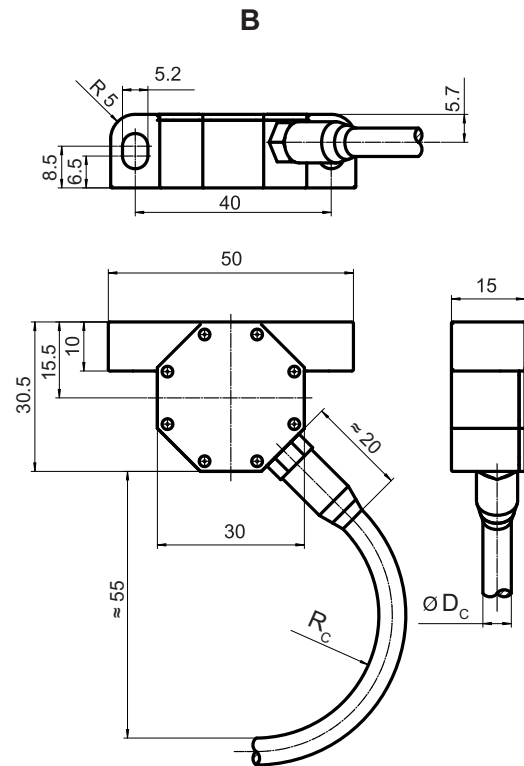

R_c Minimum bending radius dynamic (see cable data)

$\varnothing D_c$ Cable diameter (see cable data)

All dimensions stated in mm (\approx approximate dimension)

General tolerance DIN ISO 2768 medium

Assembly drawing

d Air gap
(see air gap table)

v Direction of rotation of the
tooth wheel (forward)

Signal for forward movement

All dimensions stated in mm (≈ approximate dimension)
General tolerance DIN ISO 2768 medium

Follow instructions on EMC in the operating instructions!

Air gap table

Module (m)	Permissible air gap d for
	Signal pattern V, X, T
1.00	0.2...1.2 mm
1.50	0.2...1.6 mm
2.00	0.2...2.0 mm
2.50	0.2...2.6 mm
3.50	0.2...2.8 mm
4.00	0.2...2.8 mm

Type code

Signal pattern	
V	2-channel square-wave signals with 90° phase offset, HTL
X	2-channel square-wave signals with 90° phase offset and their inverse signals, HTL
T	2-channel square-wave signals with 90° phase offset and their inverse signals, 5 V TTL / RS 422
Output circuit	
2	Push-pull power amplifier
Module	
M100	Module 1.00
M125	Module 1.25
M150	Module 1.50
M175	Module 1.75
M200	Module 2.00
M225	Module 2.25
M250	Module 2.50
M300	Module 3.00
M350	Module 3.50
M400	Module 4.00
Cable length in metres	
01	1 m
02	2 m
05	5 m
10	10 m
Cable outlet	
A	Radial, with screw sleeve
B	Lateral, with screw sleeve
248	---

Note: A Y number will be assigned for a customer-specific special design. A special design GEL 248Yxxx is manufactured to a drawing or application description, and can vary from the standard technical specification.

Your notes:



Lenord, Bauer & Co. GmbH
Dohlenstraße 32
46145 Oberhausen, Germany
Phone: +49 208 9963-0
Fax: +49 208 676292
Internet: www.lenord.com
E-Mail: info@lenord.de

Right to technical changes and errors reserved.