

2-channel speed sensor for electrically conductive target wheels

GEL 2471

Technical information

Version 2021-01

Description

- Speed sensor based on eddy current principle
- For target wheels made of electrically conductive material such as steel or aluminium with module
- Safe acquisition of creeping movements without loss of pulses and fast rotational movements
- Robust, compact stainless steel housing
- For usage in harsh applications and environments containing ferrous material
- Two tube lengths and diameters (wall thicknesses) available
- Cable fabrication to suit customer requirements

Advantages

- Maintenance and wear-free operation due to contactless measurement of rotational movements
- Weight-saving design by using measuring scale made of aluminium
- Reinforced walls in the sensor tube with 20 mm diameter ensure increased protection against impact from stones, chipping and foreign bodies



Lateral or straight cable outlet

Field of application

- Rail vehicle industry
 - Traction control
 - Anti-slip protection
 - Motor rotational speed

Output signals

Signal pattern		Pulse diagram
E	1 channel	
S	1 channel with directional signal forward backward	
V	2 channels, 90° phase offset	
X	2 channels, 90° phase offset, with inverse channels	

Right to technical changes and errors reserved.

Technical data

Signal pattern	E	S	V	X
Electrical data				
Supply voltage U_B (polarity reversal protected)	10 to 20 V DC (10 to 30 V DC upon request)			
Current consumption per channel I_B (without load)	≤ 40 mA			
Output signals (short-circuit-proof)	Square-wave signals			
Phase offset	—		typ. 90°	
Output signal level High ⁽¹⁾	$\geq U_B - 1.8$ V			
Output signal level Low ⁽¹⁾	≤ 1.5 V			
Output current per channel	≤ 20 mA			
Frequency range	0 to 20 kHz			
Duty ⁽²⁾	50 % \pm 25 %			
Dielectric strength	750 V DC (based on DIN EN 50155:2008-03)			
Environmental conditions				
Working and operating temperature	-40 °C to +120 °C			
Storage temperature	-40 °C to +120 °C			
MTTF figure	2,036,660 h at 60 °C			
Requirements on the target wheel				
Module m	2.00 / 3.00			
Air gap (for module m)	See air gap table ⁽³⁾			
Width	≥ 10 mm (smaller upon request)			
Tooth shape	Involute gear teeth according to DIN 867, square gear teeth 1:1 or slotted disc (upon request)			
Material	Steel, aluminium (others upon request)			
Electrical connection				
Connection	Cable outlet straight or lateral, flying lead			
Mechanical Data				
Sensor tube material	stainless steel			
Flange material	stainless steel			
Weight of sensor (incl. 2 m cable)	500 g			
Degree of protection (sensor without cable gland)	IP 68			
Vibration resistance	DIN EN 61373:2011-04 cat. 3			
Shock resistance	DIN EN 61373:2011-04 cat. 3			
Applicable standards				
Electromagnetic compatibility	DIN EN 50121-3-2:2017-11 Due to its inductive principle of operation, the sensor may be affected by extreme levels of RF interference and must then be screened against this interference.			
Railway applications	DIN EN 50155:2018-05			
Cable data				
Cable	halogenfree and screened ⁽⁴⁾			
Cable diameter	5.4 \pm 0.2 mm		6.5 \pm 0.3 mm	
Cable cross section	4 \times 0.5 mm ²		6 \times 0.5 mm ²	
Minimum bending radius static / dynamic	16 mm / 27 mm		20 mm / 33 mm	

⁽¹⁾ Depending on the output current and the temperature

⁽²⁾ Depending on target wheel and air gap

⁽³⁾ Depending on the wall thickness of the sensor and measuring scale material (ST: steel; Al: aluminium)

⁽⁴⁾ specification upon request

Output signal level and connection

Output signal level

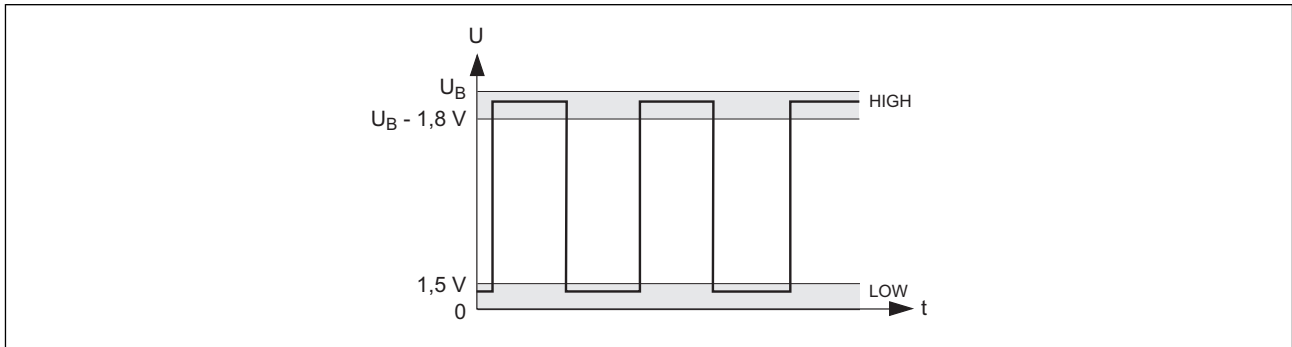

Pin layout

Signal	E	S	V	X
Channel 1	YE	YE	YE	YE
Channel 2		WH	WH	WH
Channel 1, inverse				BK
Channel 2, inverse				BN
GND (0 V)	BU	BU	BU	BU
+ U_B	RD	RD	RD	RD
Cables / screens	1 / 1	1 / 1	1 / 1	1 / 1
Screen connection according to type code Core codes: BK black, BN brown, BU blue, RD red, WH white, YE yellow				

Technical drawings

All dimensions stated in mm, general tolerance DIN ISO 2768 mK

Dimensions

2471_.....F_..... Cable outlet straight

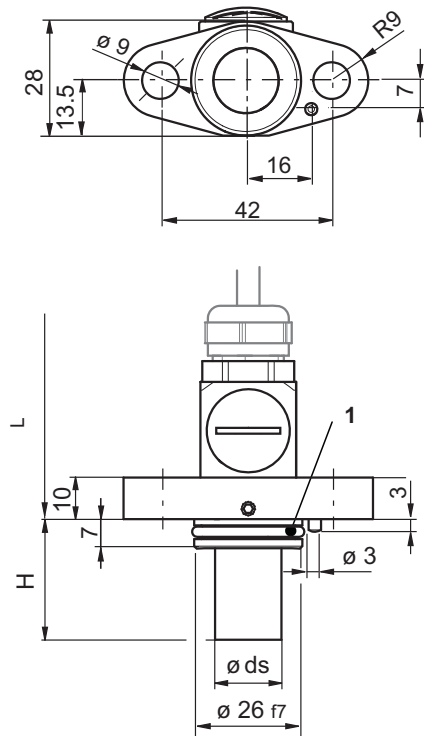

1 Sealing ring: O-ring 21 x 2.5 mm; NBR

Standard version (flying lead)

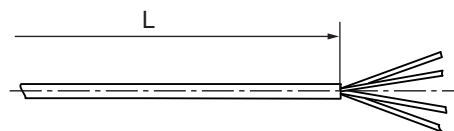

L As per type code

2471_.....G_..... Cable outlet side

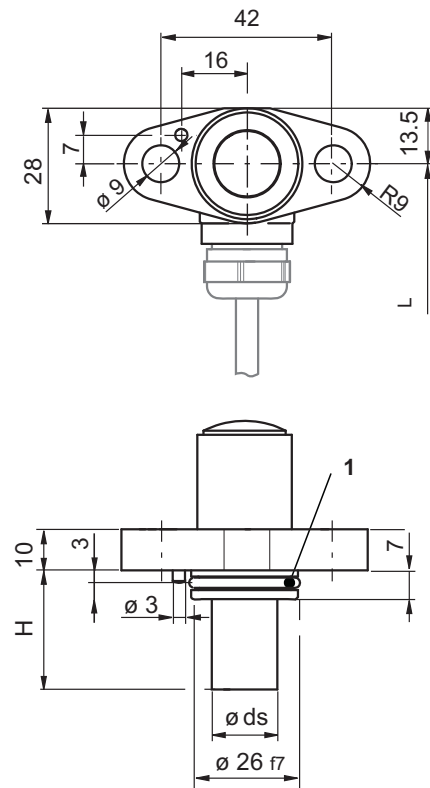

Sensor tube – dimensions

	H [mm] ^(a)	ø ds [mm]
0	29 _{-0.1}	16
1	29 _{-0.1}	20 ^(b)
2	62 _{-0.1}	16

0 Standard version
^(a) Other lengths available upon request
^(b) Available from January 2020

Technical drawings

All dimensions stated in mm, general tolerance DIN ISO 2768 mK

Assembly drawing

X Insertion chamfer
d Air gap ⁽¹⁾
1 hex socket screw (recommended: M8 x 20, EN ISO 4762)
2 Sealing ring
O-ring 21 x 2.5 mm; NBR
3 Alignment feature⁽²⁾
4 Index pin
5 Axial offset
6 Direction of rotation of the target wheel (forward)

Signal for forward movement

∅ ds [mm]	Target wheel material	d [mm]
16	Steel	0.7 ± 0.6
	Aluminium	0.8 ± 0.3
20	Steel	0.6 ± 0.5
	Aluminium	0.7 ± 0.3

Screen connection according to type code
Follow instructions on EMC in the assembly/operating instructions.

(1) Depending on the wall thickness of the sensor and measuring scale material (ST: steel; Al: aluminium)

(2) Looking at the alignment feature, the signals are output in the forward direction if the target wheel is rotating clockwise.

Technical drawings

All dimensions stated in mm, general tolerance DIN ISO 2768 mK

Hole pattern

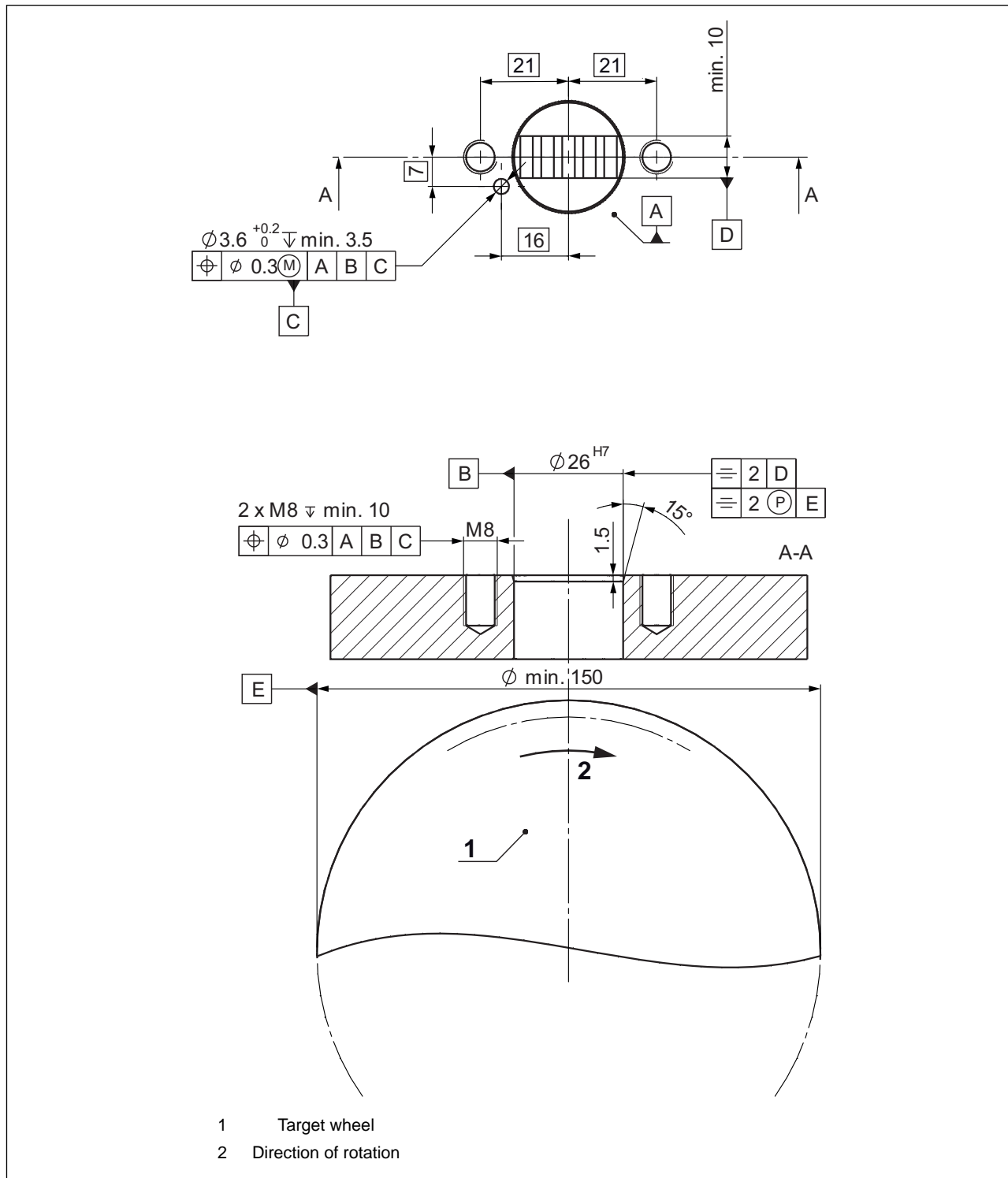

Note on target wheels with coating

In principle all target wheels made of electrically conductive material such as steel or aluminium can be used. However, surface coatings can affect the function of the sensor. With some coatings on the target wheel, the sensor must be calibrated to ensure correct function. Functional approval from Lenord+Bauer is required for steel target wheels with a coated surface.

Type code GEL 2471

		Signal pattern	
E		1-channel square-wave signals	
S		1-channel square-wave signals with direction signal	
V		2-channel square-wave signals shifted by 90°	
X		2-channel square-wave signals shifted by 90° and their inversed signals	
		Module m	
200		module 2.00	
300		module 3.00	
		Material and form of target wheel	
A		aluminium, involute gear	
B		steel, involute gear	
C		aluminium, rectangular gear	
D		steel, rectangular gear	
S		other on request	
		Cable screen	
L		connected to sensor housing	
P		not connected to sensor housing	
		Cable outlet	
F		straight	
G		lateral	
		Cable length L	
xxxx		cable length in cm	
		Customising	
N		standard version	
S		special version	
2471	-	-	-

Notes on sensor tube

- 0: Standard version Diameter d_s 16 mm; length H 29 mm
 1: Sensor tube reinforced Diameter d_s 20 mm; length H 29 mm: available from January 2020
 2: Sensor tube long Diameter d_s 16 mm; length H 62 mm

If you require a sensor tube different to the standard version, please state on the order.
 In principle, other sensor tube lengths are available upon request.

Special designs

A Y number is assigned for every customer-specific special design. A special design GEL 2471Yxxx is manufactured to a drawing or application description, and can vary from the standard technical specification.

We manufacture for you upon request:

Examples for the sensor end

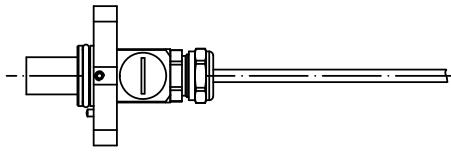

Standard, without cable protection, outlet straight

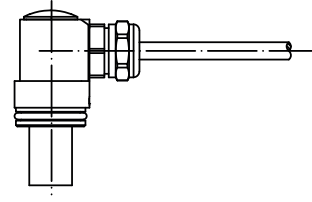

Standard, without cable protection, outlet side

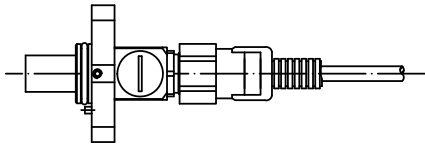

Flexible conduit, outlet straight

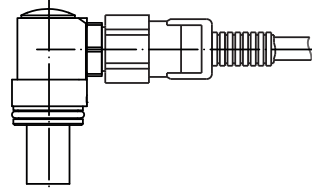

Flexible conduit, outlet side

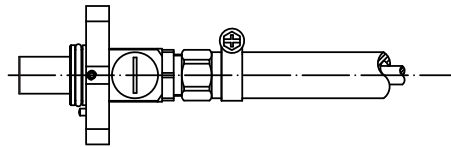

Rubber sleeve, outlet straight

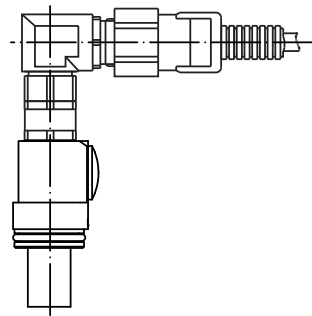

Flexible conduit, outlet straight with 90° angle

Examples for the cable end

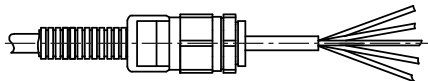

Flexible conduit and flying lead

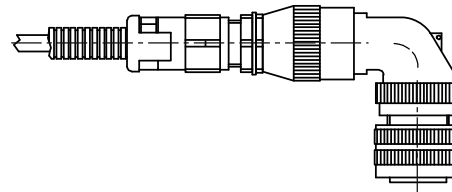

Flexible conduit with angled round connector

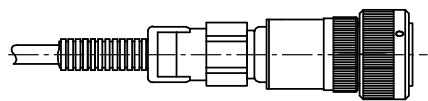

Flexible conduit with round connector

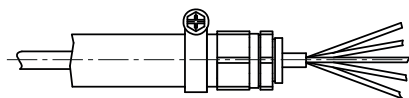

Rubber sleeve and flying lead

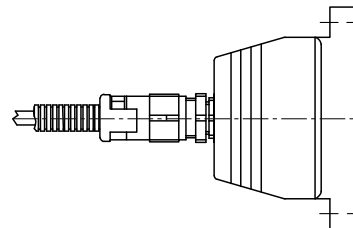

Flexible conduit with rectangle connector (HTS plug)