



### Functional description

- Measurement of speed and position by proximity sensing of precision target wheel
- Scanning by means of magnetoresistive sensor elements
- Measuring unit consisting of sensor and precision target wheel for installation on shafts with diameters ranging from 8 mm to more than 500 mm

### Applications

- Speed detection in HSC spindles (High-Speed-Cutting)
- Measurement of speed and position of milling and grinding spindles in machine tools for the machining of metal, wood, glass, stone and aluminium
- Angle measurement in radar equipment
- Electronic synchronization of helical spindles in dry-running vacuum pumps
- Measurement of speed in test stands

### Special features

- Sufficient scope for construction due to customer-specific production of precision target wheels
- Internal production of target wheels with module 0.3 and 0.5 from speeds from 0 to more than 70,000 min<sup>-1</sup>
- **Safety integrated** certificate
- Output signal 1 V<sub>pp</sub> with high signal quality (sin/cos)
- Cable outlet axial or radial
- Sensor fully encapsulated
- Very compact

### Measuring principle

- Integrated MR-sensors for contactless scanning of target wheel
- Sensor signals internally amplified and temperature-compensated
- Frequency range from zero to max. 200 kHz

### Output signals

- Outputs short-circuit-proof
- Signal forms:
  - two signals phase-shifted by 90° for sense-of-rotation detection
  - sine-wave signal 1 V<sub>pp</sub>
  - all signals additionally available as inverted signals
  - option: reference pulse

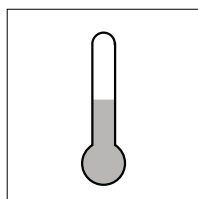

-40 ... +120°C

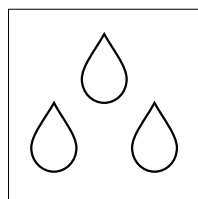

IP 68

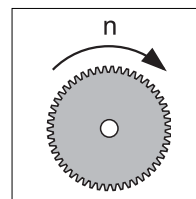

n = 0 ... > 70,000 min<sup>-1</sup>

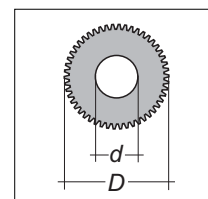

D = 22 ... > 500 mm  
d ≥ 8 mm

# Technical data GEL 2442



Output level	1 V <sub>pp</sub> as differential signals
Output signals	two sine-wave signals, by 90° out of phase, and their inverse signals short-circuit-proof, option: reference pulse
Output frequency	0 ... 200 kHz for C <sub>L</sub> = 5 nF
Offset (static)	± 20 mV
Amplitude tolerance	-20 ... +10 %
Amplitude ratio U <sub>A</sub> /U <sub>B</sub>	0.9 ... 1.1
Supply voltage U <sub>B</sub>	5 V DC ± 5%
Power consumption without load	≤ 0.3 W
Permissible air gap	0.15 mm ± 0.02 mm with module 0.3 0.20 mm ± 0.03 mm with module 0.5
Width of target wheel	min 4.0 mm
Material of target wheel	ferromagnetic steel
Operating temperature range	-30°C ... +85°C
Ambient and storage temperature range	-40°C ... +120°C
Protection class	IP 68
Electromagnetic compatibility	EN 61000-6-1 to 4*)
Insulation strength according to EN 60439-1	500 V
Vibration resistance (IEC 68-2-6)	200 m/s <sup>2</sup>
Shock resistance (IEC 68-T2-27)	2000 m/s <sup>2</sup>
Weight	30 g
Housing material	polyphenylene sulfide (PPS), glassfibre reinforced
Connection	9-core cable, cross section 0.15 mm <sup>2</sup> , outside diameter 5 mm(-0.3), min. bending radius 25 mm

The technical data provided are valid for the operating temperature range.

\*) Important: Where possible, connections to the cable screen should be made coaxially. Connections to the cable screen using single wire cores should be kept as short as possible.

# Dimensional drawing, Boring and milling diagram

### Dimensional drawing

Axial cable outlet

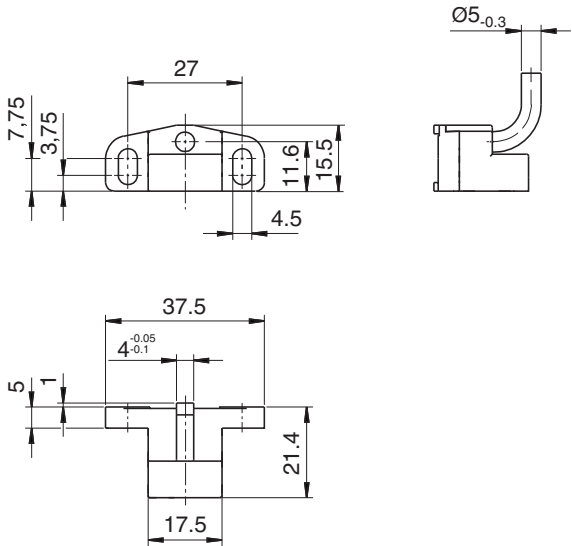

### Dimensional drawing

Radial cable outlet

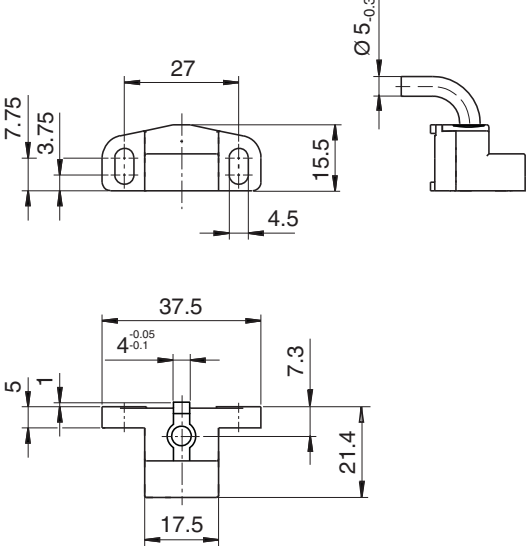

### Boring and milling diagram

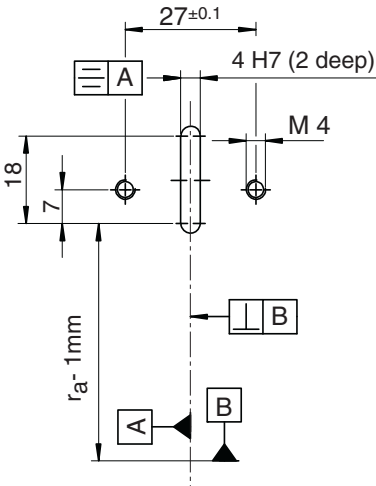

$r_a = d_a/2$ ;  $d_a = \text{OD of target wheel}$

# Type code, Description

<b>Signal patterns</b>									
<b>K</b> Sine/Cosine signals 1 V <sub>pp</sub>									
<b>Reference mark</b>									
- without reference mark									
<b>N</b> tab									
<b>M</b> groove									
<b>Z</b> tab over groove									
<b>Cable outlet</b>									
<b>R</b> radial									
<b>G</b> axial									
<b>Module</b>									
3 0.3									
5 0.5									
<b>Connection type</b>									
<b>K</b> cable end open (cable length 30, 150, 250, 600 cm)									
<b>A</b> 17-pole plug (pin) straight type, cable length to be specified in cm									
<b>B</b> 17-pole plug (pin) elbow type, cable length to be specified in cm									
<b>Cable length (cm)</b>									
<b>Cable for temperature sensor (2 m)</b>									
<b>M</b> with									
- without									
<b>Additional screen connection on sensor head</b>									
2442	-	-	1	-	-	-	-	-	E-

**K** = signal pattern sine/cosine-signals 1 V<sub>SS</sub> (pin layout)

		<b>K</b>	<b>KM</b> <b>KN</b>
U <sub>A+</sub>	track 1		
U <sub>A-</sub>	track 1		
U <sub>B+</sub>	track 2		
U <sub>B-</sub>	track 2		
U <sub>N+</sub>	N		
U <sub>N-</sub>	N̄		

**N** = reference mark (flag)

**M** = reference mark (groove)

A metal flag integrated in the target wheel is detected when its position is exactly between two teeth. This reference signal can be used as a position reference. This is required, for instance, for the automatic changing of a tool in a milling or grinding spindle.

Depending on size and geometry of the target wheel, the target wheel version with a reference tab can only be used up to certain speeds. For speeds beyond 30.000 min<sup>-1</sup>, a MiniCoder detecting a reference groove integrated in the target wheel is used. For technical reasons, the target wheel is in this case composed of two parts.

h = 4 mm  
b = 0.5 mm

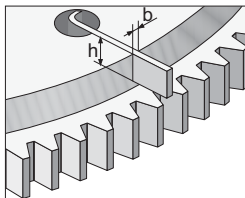

h = 1 mm

Module	b
0.3	1.2 mm
0.5	1.6 mm

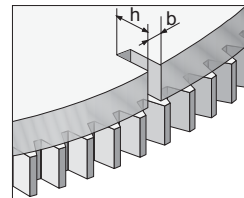

# Type code, Description

**Z** = Reference mark (flag over groove)

This MiniCoder version can be used for scanning a target wheel manufactured in one piece. The system permits reaching speeds of more than 70.000 min<sup>-1</sup>. The reference flag is in alignment with a tooth of the pulse track.

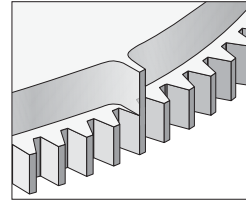

**1** = Internal multiplier

When the MiniCoder is used, the interpolation of the 1 V<sub>PP</sub> output signals is generally performed in the respective control unit used. If the control unit does not have this feature, Lenord + Bauer is in a position of supplying the GEL 214 series with independent interpolation electronics which converts the 1 V<sub>PP</sub> output signals into TTL square-wave signals (maximum interpolation factor = 512). Please ask for the corresponding documentation or just take a look at our website at [www.lenord.de](http://www.lenord.de) from where the above documentation can also be downloaded.

**G** = Axial cable outlet

**R** = Radial cable outlet

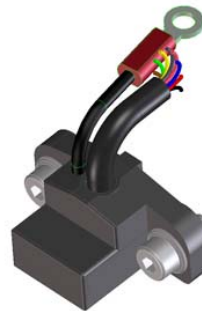
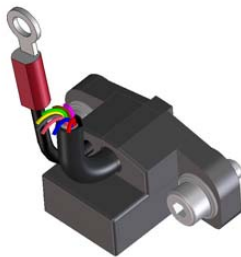

**3** = Module 0.3

**5** = Module 0.5

The module describes the relation between the number of teeth and the outer diameter of a target wheel. The smaller the module the smaller the outer diameter for the same number of teeth.

The air gap to be observed between sensor and target wheel is less with module 0.3 than with module 0.5.

$$d_a = m \cdot (z+2)$$

$d_a$  = outer diameter  
 $m$  = module  
 $z$  = number of teeth

The MiniCoder must be ordered compatible with the target wheel.

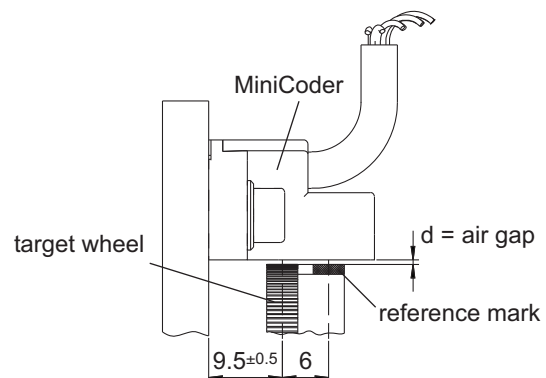

module	air gap d adjustment dimension	distance tolerance
0.3	0.15	± 0.02 mm
0.5	0.20	± 0.03 mm

# Type code, Description

**Connection type K = cable end open**

The MiniCODER are manufactured with open cable end. The following cable length are available (30/150/250/600 cm).

**GEL 2442**

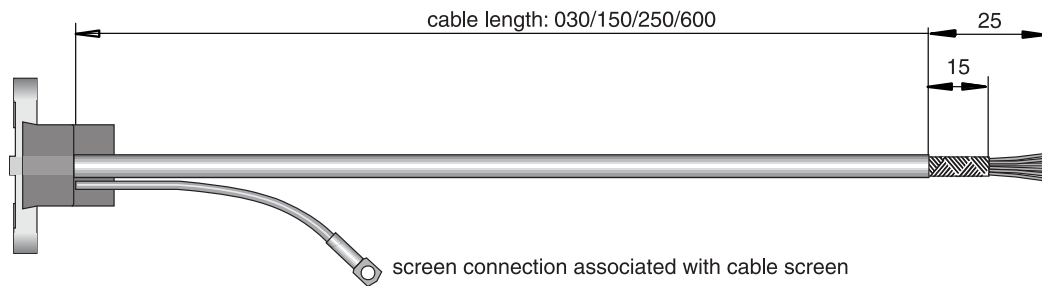

Important: Fit the cable screening as coaxially to the earth cable as possible. When fitting the cable screening onto an earth cable, the earth cable should be run as short as possible.

Colour	Function	
	white	$U_{A+}$
brown	$U_{A-}$	track 1
gray	$U_{N+}$	N
blue	0 V GND	0 V GND
red	$U_B = 5 V$	$U_B = 5 V$
pink	$U_{B+}$	track 2
black	$U_{B-}$	track 2
yellow	$U_{N-}$	N
green	5 V Sense	5 V Sense

# Type code, Description

**Connection type A** = 17-pole male plug, straight type, **B** = 17-pole male plug, elbow type

Ready-made cable variants with 17-pole male connector (straight type, elbow type) are available on the market.

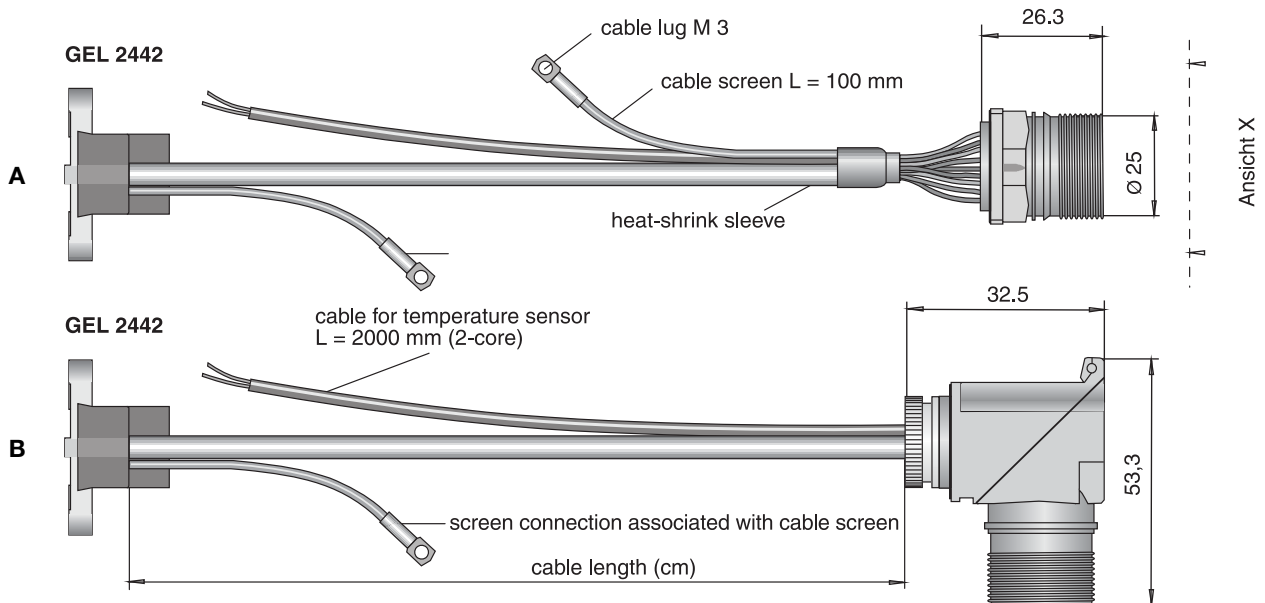

Important: Fit the cable screening as coaxially to the earth cable as possible. When fitting the cable screening onto an earth cable, the earth cable should be run as short as possible.

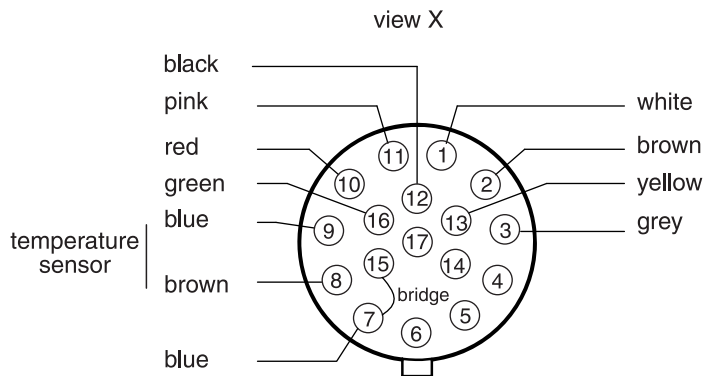

Pin	Colour	Function	
1	white	$U_{A+}$	<u>track 1</u>
2	brown	$U_{A-}$	<u>track 1</u>
3	grey	$U_{N+}$	N
4	n. c.		
5	n. c.		
6	n.c.		
7	blue	0 V GND	0 V GND
8	brown	Temp+	Temp+
9	blue	Temp-	Temp-
10	red	$U_B = 5 V$	$U_B = 5 V$
11	pink	$U_{B+}$	<u>track 2</u>
12	black	$U_{B-}$	<u>track 2</u>
13	yellow	$U_{N-}$	$\bar{N}$
14	n. c.		
15	jumpered with 7	0 V GND	0 V GND
16	green	5 V Sense	5 V Sense
17	n.c.		

The examples illustrated show different ways of connecting the cable screen. Depending on the control type and the connecting cable used, a different screen connection may be necessary.

# Type code, Description

## \_\_\_ = Cable length (cm)

For connection type K= cable end open, 4 cable length are available: 30, 150, 250, 600 cm. For ready-made connecting cables with male connectors, the length of the cable is to specified in cm.

Cable type: PUR cable 9 x 0.15 mm<sup>2</sup> screened  
Screen not connected on MiniCoder side  
Outside diameter: 5 mm (-0.3)  
Min. bending radius: 25 mm

## M = cable for temperature sensor (2 m)

Variants A and B (see page 7) can be delivered on request with the cable for the temperature sensor connected to the mating connector.

Cable type: TEFLON cable 9 x 0.14 mm<sup>2</sup>  
Outside diameter: 2.8 mm ( $\pm 0.1$ )  
Min. bending radius: 20 mm

## E- = Additional screen connection on sensor head.

This screen connection is connected to the screen of the sensor cable. In order to improve electromagnetic compatibility (EMC), the screen connection should be connected to the flange on which the MiniCoder is mounted.

# Custom-made target wheels

## Standard target wheels

### Custom-made target wheel

Target wheel are made to individual specifications on request of the customer. Please send us a dimensional drawing of your target wheel (if possible, as a dxf-file) the inquiry form on page a 11 to [info@lenord.de](mailto:info@lenord.de).

### Target wheels

For detecting rotary movements, the MiniCoders and target wheels form a complete unit. The target wheel size and hence , its diameter are directly dependent on the module and the number of teeth, i.e.:

$$z = (d_a / m) - 2$$

$$d_a = m \cdot (z+2)$$

Standard target wheels (see table) are available at short noticeex factory.

### Table standard target wheels

number of teeth z	module m [mm]	OD-Ø d <sub>a</sub> [mm]	ID-Ø standard [mm]	ID-Ø di max. [mm]	collar-Ø dr [mm]
100	0.5	51.0	12 H7	30 H7	47
125	0.5	63.5	12 H7	35 H7	60
128	0.5	65.0	12 H7	35 H7	61
200	0.5	101.0	12 H7	70 H7	97
250	0.3	75.6	12 H7	45 H7	72
250	0.5	126.0	25 H7	85 H7	122
256	0.3	77.4	12 H7	50 H7	74
256	0.5	129.0	25 H7	90 H7	125
360	0.3	108.6	25 H7	70 H7	105
500	0.3	150.6	25 H7	110 H7	147
512	0.3	154.2	25 H7	110 H7	151

### Dimensional drawing target wheel

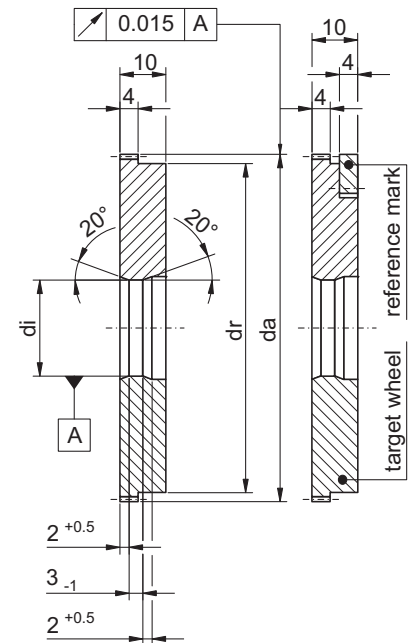

### Type code for standard target wheels

ZA	-	-	-	-	reference mark with reference mark
					reference mark without reference mark
					module 3 module 0.3 5 module 0.5
					number of teeth 0100 e. g. (see chart at the top)
					inside diameter 012.0 e. g. (see table above)

# Reply-Fax

## Custom-made target wheel



**Fax: +49 (0)208 676292**

### Transmitter

Name:	.....	Contact/person in charge:	.....
Street:	.....		.....
Postal code/City:	.....		.....
Phone:	.....	Phone:	.....
Fax:	.....	Fax:	.....

### Target wheel

Form of target wheel	<input type="checkbox"/> A <input type="checkbox"/> B <input type="checkbox"/> C	Width of target <b>zb</b> ( $\geq 4$ mm)	..... mm
	<input type="checkbox"/> AN	$\emptyset$ right <b>dr</b>	..... mm
	<input type="checkbox"/> BN		( $\leq da - 29$ mm with zero flag)
	<input type="checkbox"/> CN	$\emptyset$ left <b>dl</b>	..... mm
Tooth number	<b>z</b> .....	Collar right <b>br</b>	..... mm
Module	<b>m</b> <input type="checkbox"/> 0.3 <input type="checkbox"/> 0.5	Collar left <b>bl</b>	..... mm
$\emptyset$ OD	<b>da</b> = $m(z+2)$ ..... mm	Reference mark (flag)	<input type="checkbox"/> yes <input type="checkbox"/> no
$\emptyset$ ID	<b>di</b> + Tolerance field ..... mm	Referenc mark (groove)	<input type="checkbox"/> yes <input type="checkbox"/> no
$\emptyset$ Shaft	<b>dw</b> + Tolerance field ..... mm	Revolution $n_{max}$	..... $min^{-1}$
		Purchase quantity	..... pieces

### Hole circle/bores for mounting

Thread bore  
  Through bore  
  Cylindrical counterbore  
  Conical counterbore

$\emptyset$ Hole circle	<b>lk</b> ..... mm
$\emptyset$ Bore/thread	<b>b</b> ..... mm
$\emptyset$ Bore	<b>b<sub>1</sub></b> ..... mm
Depth	<b>t</b> ..... mm
Number of bores	.....

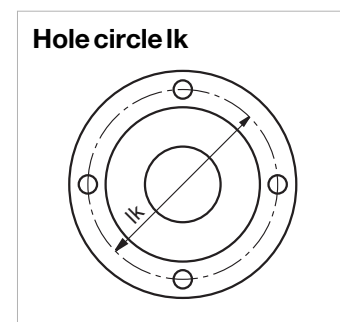

Additional remarks

.....

.....

.....

.....

.....

.....

.....

.....

**Target wheels**

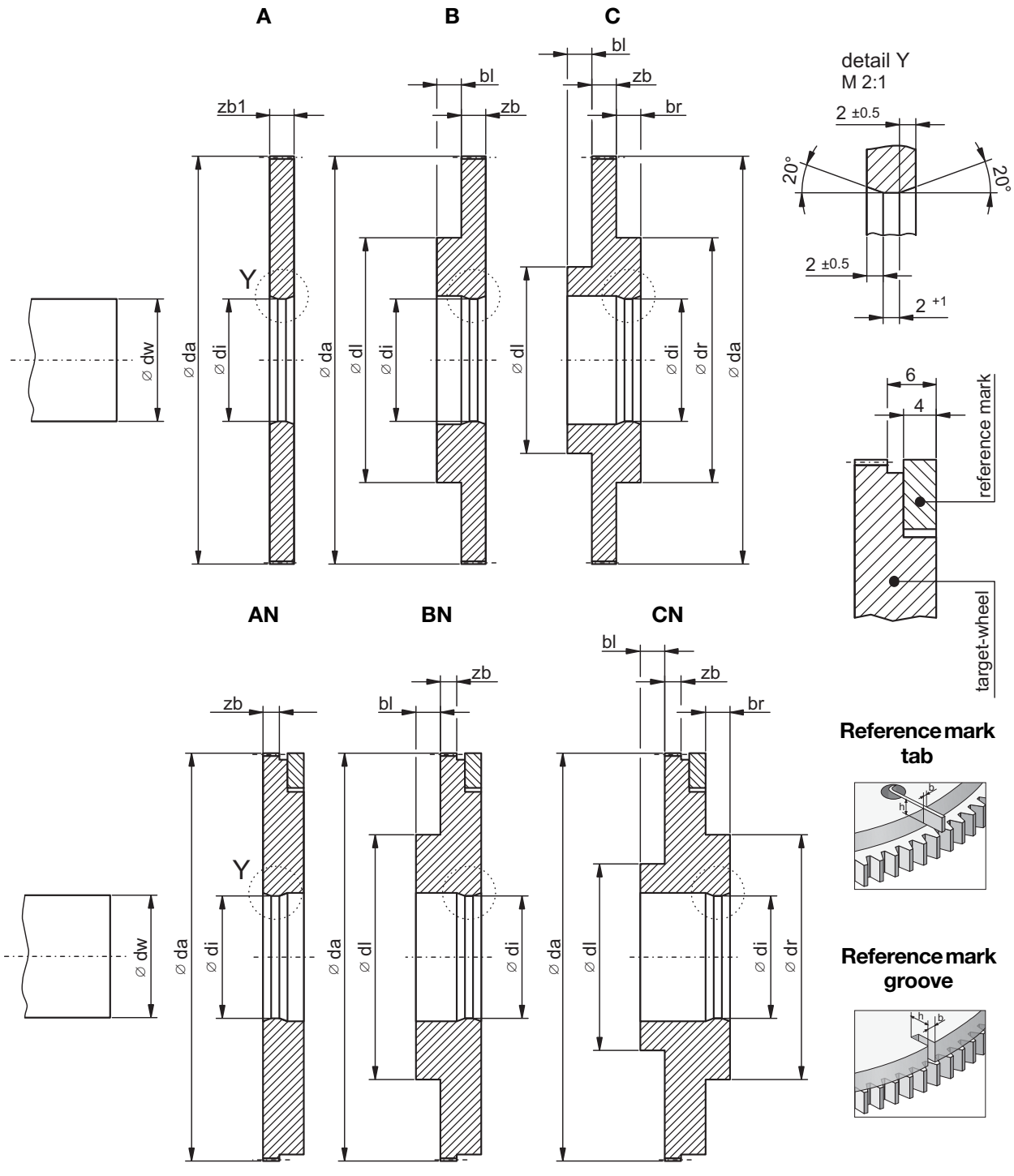

**Bores for mounting**

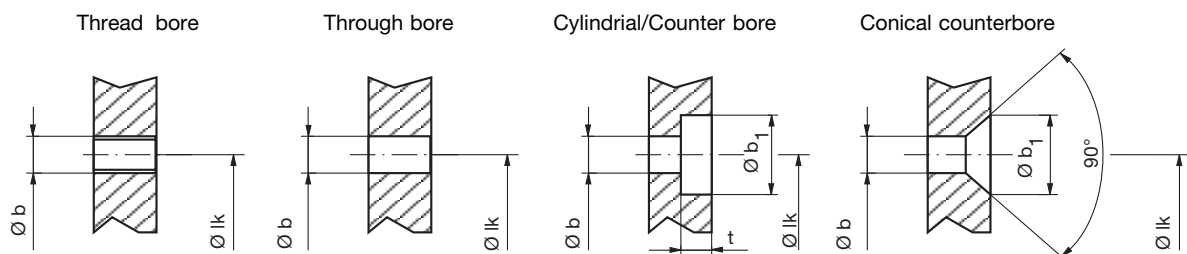

We have agencies in:

Austria  
Belgium  
Canada  
Czech Republic  
Denmark  
Finland  
France  
Germany  
Great Britain  
Israel  
Italy  
Korea  
Malaysia  
Netherlands  
Norway  
Portugal  
Sweden  
Switzerland  
Spain  
Turkey  
USA

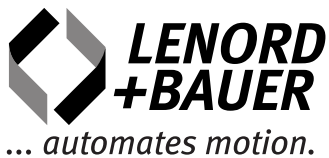

Lenord, Bauer & Co. GmbH  
Dohlenstrasse 32  
46145 Oberhausen, Germany  
Phone: +49 208 9963-0  
Fax: +49 208 676292  
[info@lenord.de](mailto:info@lenord.de)  
[www.lenord.de](http://www.lenord.de)

Subject to technical modifications and typographical errors.  
For the latest version please visit our web site : [www.lenord.de](http://www.lenord.de).