



Target wheels and measuring rods can be supplied separately.

Key features

- Contactless measurement of linear or rotational movements
- One or two channels
- Magnetic measurement principle
- Optionally available with:
EC type-examination certificate
BVS 07 ATEX E 030
Ex II 2 G Ex ib IIB T 4

Features

- Can be used under very harsh conditions
- Registers speed between 0 Hz and a maximum of 25 kHz
- Uses target wheels with modules 1.0 to 3.5 (D.P.= 25.4 - 7.3) or measuring rods with 4.0 mm pitch
- Large measuring distance (air gap) of up to 3 mm (depending on the gear module or the pitch of the target)
- Very precise duty and phase shift of the output signals
- Robust stainless steel housing
- Very high protection class IP 68
- Wide temperature -40°C to + 85°C (ATEX)
or -40°C...+120°C without ATEX certificate

Fields of application

- Speed and position measurement in machines and motors
- Position measurement on piston rods
- Speed and position measurement in explosion-hazardous areas

Technical data

Electrical data	
Supply voltage V_s	10 ... 28 V DC (ATEX); $V_s = 10 \dots 30$ V DC without ATEX certificate, protected against polarity reversal
Safety-related parameters	See section "Safety information"
Power consumption without load	$I_B < 45$ mA
Output signal	Square-wave, short circuit-proof
Output voltage	High = $V_s \cdot 1.8$ V; Low = $U < 0.5$ V
Slew rate of output signal	> 10 V / μ s
Maximum output current per channel	< 10 mA
Frequency range	0 Hz... 25 KHz
Duty ratio of output signal	50 % \pm 5 %
Phase shift tracks 1 and 2	90° \pm 20°
Electromagnetic compatibility	rail vehicles: EN 50121-3-2 industry applications: EN 61000-6-1 to 4
Mechanical data	
Isolation strength (EN 60439-1)	500 V AC
Vibration protection (EN 61373 Kat.3)	200 m/s ²
Shock protection (EN 61373 Kat.3)	2000 m/s ²
Air gap	See table "Air gap"
Module of target wheel / Pitch of measuring rod	M = 1.0 ... 3.5 p = 4.0 mm
Operating and ambient temperature range	-40 °C ... + 85 °C (ATEX) or -40°C ... +120°C without ATEX certification
Storage temperature range	-40 °C ... + 120 °C
Screen connection	Connected to sensor housing
Cable	PUR or silicone depending on the version *)
Type of connection	6-core cable outlet (see cable assignment)
Cable cross-section	6 x 1.0 mm ² (PUR), 6 x 0.75 mm ² (silicone),
External diameter of cable	$d_a = 8.1$ mm \pm 0.2 mm (PUR) or $d_a = 9.2$ mm \pm 0.4 mm (silicone)
Protection class	IP 68
Housing	Stainless steel; material 1.4305
Resistance of the measuring side	< 5 bar









*) Cable specification:
LK 1069 = PUR
LK 10581 = silicone on request

Air gap depending on module or pitch

Measuring scale	Module / Pitch	Air gap
Measuring target wheels	M = 1.0	a = 0.2 ... 1.4 mm
	M = 1.5	a = 0.2 ... 1.8 mm
	M = 2.0	a = 0.2 ... 2.2 mm
	M = 2.5	a = 0.2 ... 2.8 mm
	M = 3.5	a = 0.2 ... 3.0 mm
Measuring rods	p = 4.0 mm	a = 0.2 ... 1.0 mm

Cable assignment, Dimension drawing

Cable assignment

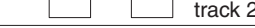
Signal pattern (see type code)	Function	PUR cable LK 1069	Silicone cable LK 10581
E	 track 1	yellow	6
	0 V, GND	blue	4
	V_s *)	red	1
F	 track 1	yellow	6
	 track 1	black	5
	0 V, GND	blue	4
	V_s *)	red	1
V	 track 1	yellow	6
	 track 2	white	3
	0 V, GND	blue	4
	V_s *)	red	1
X	 track 1	yellow	6
	 track 1	black	5
	 track 2	white	3
	 track 2	brown	2
	0 V, GND	blue	4
	V_s *)	red	1

*) $+V_s = 10 \dots 28$ V DC with ATEX certification
 $+V_s = 10 \dots 30$ V DC without ATEX certification

Dimension drawing

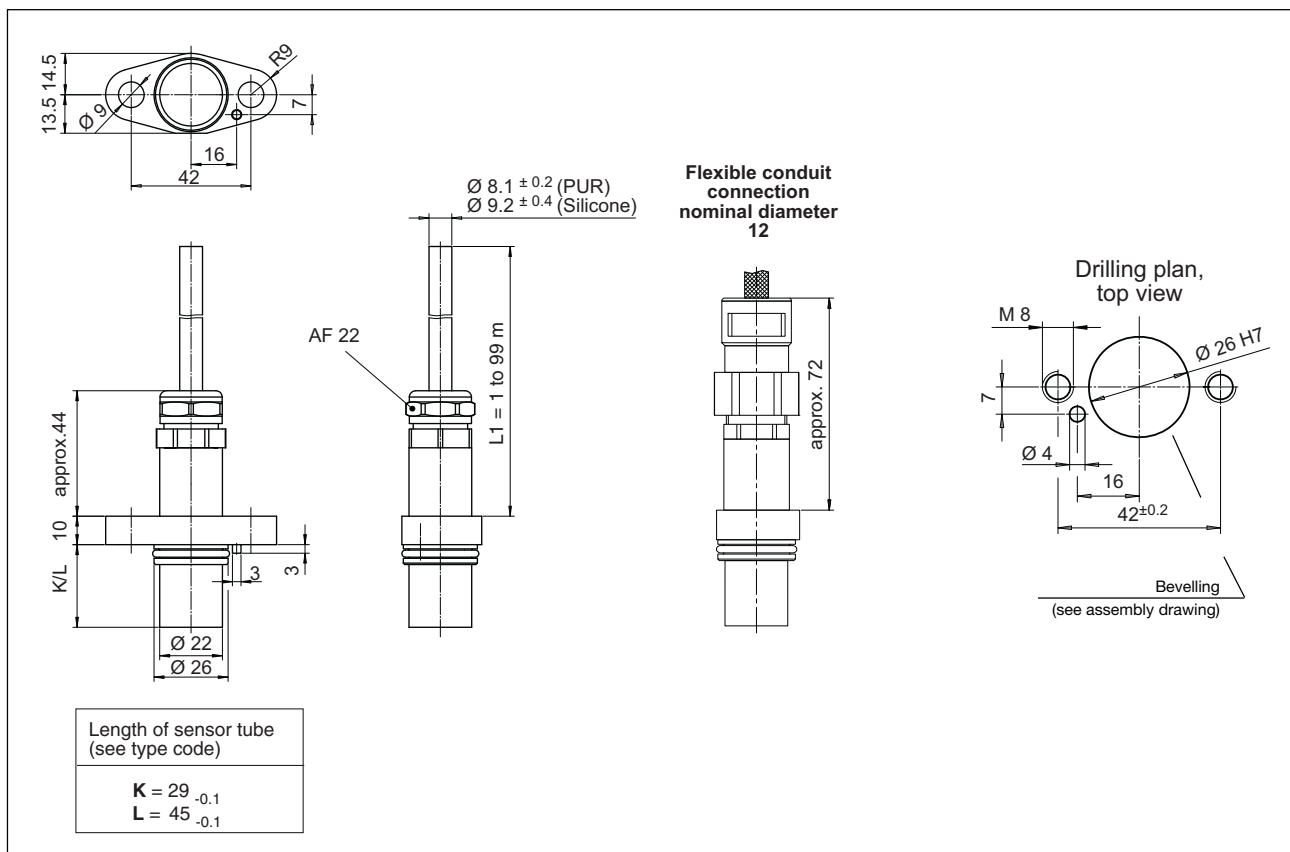

Assembly drawing for scanning target wheels

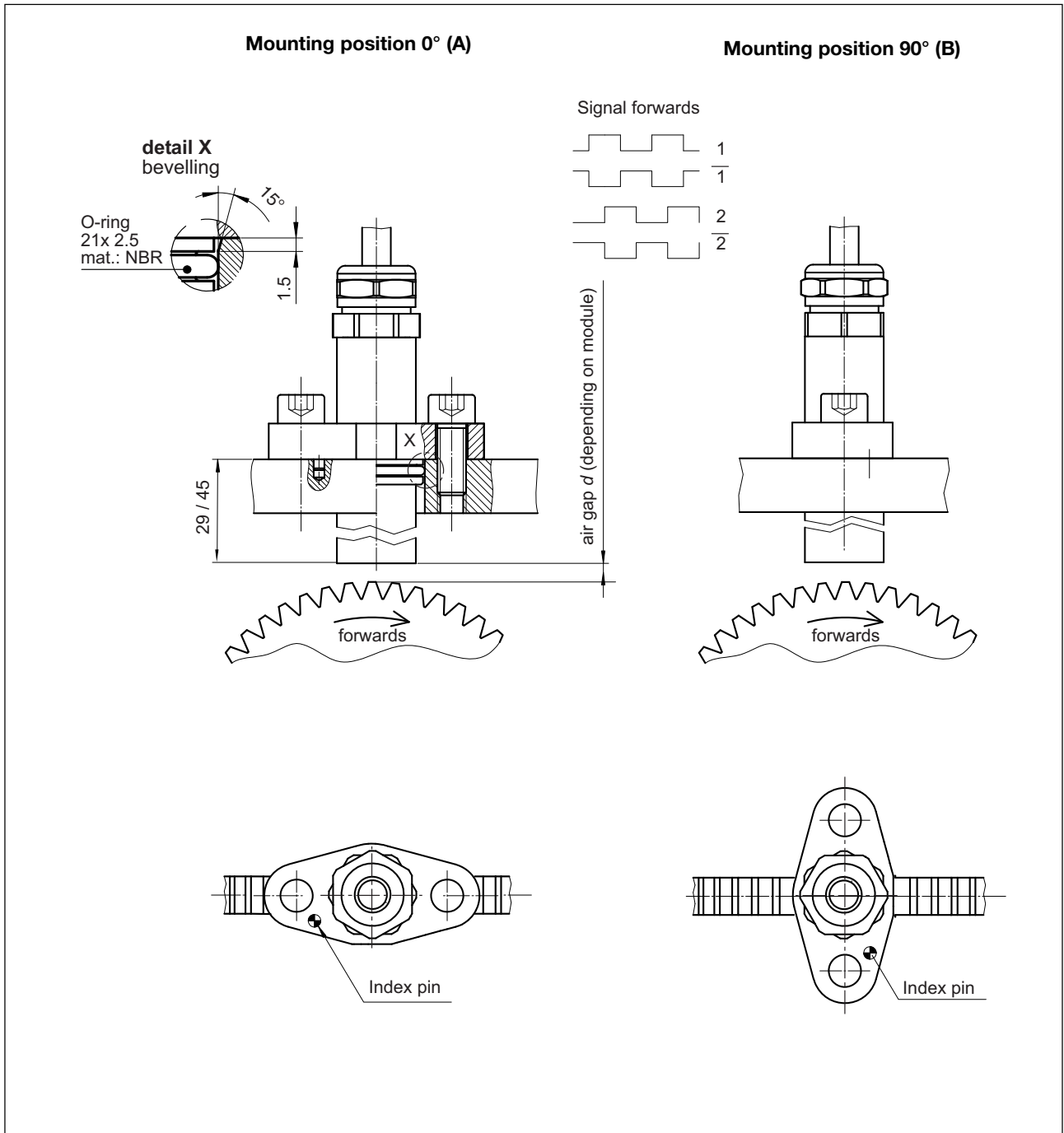

Assembly drawing for scanning measuring rods

Mounting position 0° (A)

Mounting position 90° (B)

detail X
beveling

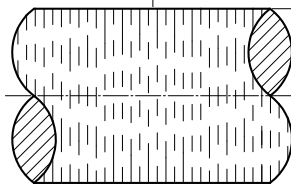
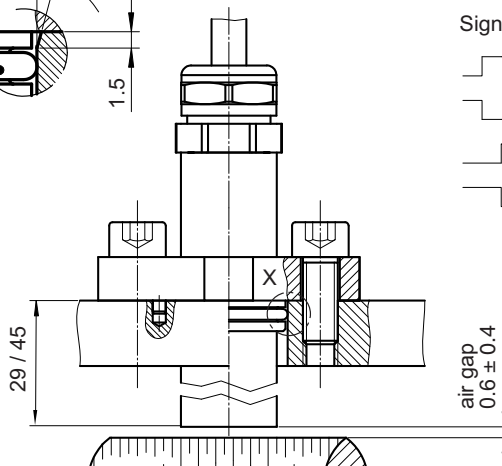
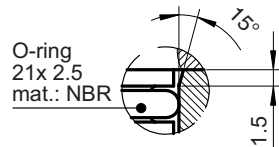

pitch p = 4 mm

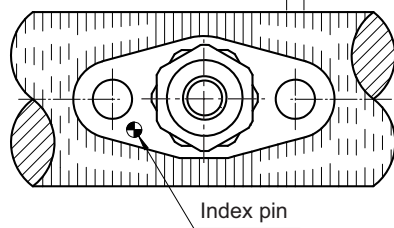

forwards

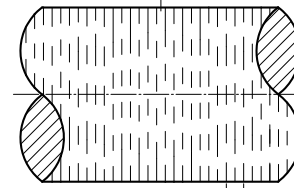
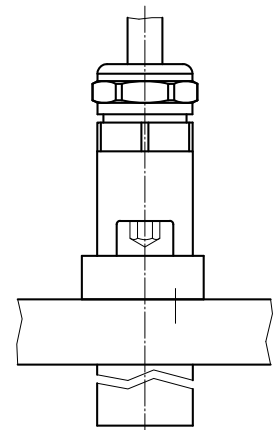
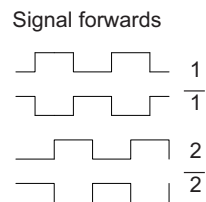

pitch p = 4 mm

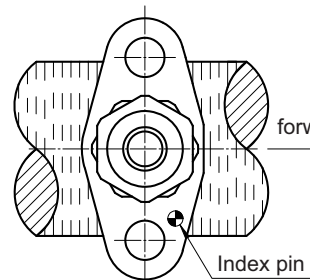

forwards

Safety information

The following information must be observed when using sensors of type GEL 2478_Z with ATEX certificate in explosion-hazardous areas.

The maximum electrical and mechanical limiting values given in the technical data may not be exceeded. The following **safety parameters** apply to the GEL 2478 sensor:

Ignition protection type: IIG Ex ib IIB T4	
$U_i \leq$	28 V DC
$I_i \leq$	250 mA
$P_i \leq$	1000 mW
$L_i =$	0 mH
$C_i =$	480 nF
Cable characteristics:	
$L_c =$	0,018 mH / 100 m
$C_c =$	18 nF / 100 m

The sensor may be operated only within the specified operational temperature range, namely $-40^{\circ}\text{C}.. + 85^{\circ}\text{C}$. The cables between the power inlet and the GEL 2478 sensor and between the sensor and the external evaluation unit may not exceed the specified maximum length. Connection and installation of the safety barriers may be carried out only by certificated personnel; installation of modules relevant to explosion hazards may be carried out only by authorised expert technicians. The cables and housing of the GEL 2478 sensor must be undamaged: in the event that these elements are damaged then the unit may not be installed.

Type-examination:

EC type-examination certificate **BVS 07 ATEX E 030** for sensor type GEL 2478_Z dated 09.03.2007.

The certificate is available on request.

Description of a protective circuit as shown in the example (see next page).

The power supply is connected to the 9002/13-280-110-001 safety barrier. This safety barrier limits the current flowing in the EEX circuit to at most 119 mA and the voltage to at most 28 V. The output signals from the GEL 2478 sensor are connected to the 9002/11-120-024-001 safety barrier. In the event of a malfunction, this barrier limits the current to at most 12 mA and the voltage to at most 12 V. The 9002/11-120-024-001 safety barrier routes each of the output signals to a DEK 0E 5DC/ 24CD/1 00 kHz optocoupler. These optocouplers serve to convert the output signals back to a range that can be evaluated by the SPS.

Summary of the resource parameters

Nr.:	Corresponding resource		Manu- facturer	U_o [V]	I_o [mA]	P_o [mW]	L_o [mH]	C_o [nF]	Ex Group
	Designation	Type							
1	Safety barrier	9002/13-280-110-001	Stahl	28	110	770	9	635	IIB
2	Safety barrier	9002/11-120-024-001	Stahl	12	24	70	230	7100	IIB

Optocoupler:

DEK 0E 5DC/24DC/100 kHz; article no.: 29 64 27 0

Supplier: Phoenix Contact GmbH & Co.KG; Blomberg

Type code

		Signal pattern					
		E One square-wave signal					
		F One square-wave signal and inverse signal					
		V Two square-wave signal, 90° offset					
		X Two square-wave signal, 90° offset, with inverse signals					
		Certification					
		W with no certification					
		Z with ATEX certification, Ignition protection II 2G Ex ib IIB T4					
		Module M / Pitch P					
		M100 Module 1.00					
		M125 Module 1.25					
		.					
		.					
		M350 Module 3.50					
		P400 Pitch 4 mm					
		Length of sensor tube					
		K 29 mm					
		L 45 mm					
		Mounting position					
		A 0° (target wheels and rods)					
		B 90°(only rods)					
		Type of cable					
		N 6 x 1 mm ² PUR cable jacket (LK 1069)					
		S 6 x 0.75 mm ² Silicone cable jacket(LK 10581)					
		Cable outlet					
		K Cable gland					
		W Flexible conduit connection					
		xx Length of cable (m)					
2478	-	-	-	-	-	-	-