

2-channel speed sensor

▶ GEL 2475

Sensor with current output or voltage output (standstill voltage)

SENSORLINE

▶ **LENORD+BAUER**

Technical information

Version 03.10



General

- ▶ Application approved speed sensor based on magnetic measurement principle
- ▶ Maintenance- and wear-free operation due to non-contact measurement of rotation
- ▶ Suitable for ferromagnetic target wheels
- ▶ Safe detection of slow rotation from 0 Hz without pulse loss and for high-speed rotation up to 25 kHz
- ▶ Two channels shifted by 90° provide the direction of rotation
- ▶ Robust and compact stainless steel housing suitable for harsh application
- ▶ Constant duty output signals
- ▶ Customized cable fittings

Features

- ▶ Modul target wheel 1.00 to 3.50
- ▶ Measuring range 0 Hz to 25 kHz
- ▶ Temperature range -40 to +120 °C
- ▶ Protection class IP 68
- ▶ Type testing according to EN 50155

Advantages

- ▶ Current output signals unsusceptible to electromagnetic disturbances
- ▶ Cable break monitoring by current output or voltage output with standstill voltage
- ▶ Maintenance-free due to significant measuring distance (air gap up to 3 mm)

Fields of application

- ▶ Rail vehicles
 - Traction control
 - Anti-slip
 - Anti-skid
- ▶ Automation
 - Measurement of speed and positions at gears, motors and roller

Technical data

Signal pattern	D-	H-	S-	V-
Electrical data				
Supply voltage V_S (reverse polarity protected)	10 to 30 V DC			
Current consumption per channel I_S (without load)	≤ 30 mA			
Output signal (short circuit proof)	square-wave signals			
Output signal high ⁽¹⁾	≥ $V_S - 1.8$ V		≥ $V_S - 1.0$ V	
Output signal level low ⁽¹⁾	≤ 1.5 V		≤ 1.0 V	
Output current per channel	≤ 20 mA			
Input frequency target wheel	0 to 25 kHz			
Output frequency	0 to 25 kHz			
Duty (depends on measuring scale and air gap)	50% ± 5%			
Phase shift	typ. 90°		–	typ. 90°
Slew rate (2 m cable)	≥ 10 V / μs			
Electromagnetic compatibility	rail vehicles(EN 50121-3-2) industrial applications (EN 61000-6-1 to 4)			
Insulation	500 V AC (EN 60439-1)			
Mechanical data				
Module m target wheel	1.00 / 1.25 / 1.50 / 1.75 / 2.00 / 2.25 / 2.50 / 3.50			
Permissible air gap (for module m) ⁽²⁾	0.2 to 3.0 mm			
Width of target wheel	≥ 10 mm (smaller ones on request)			
Form of target wheel	involute gear as per DIN 867, rectangular gear 1:1 or slotted disk (on request)			
Material of target wheel	ferromagnetic steel			
Operating and ambient temperature	-40 °C to +120 °C			
Storage temperature	-40 °C to +120 °C			
Protection class	IP 68			
Vibration resistance	EN 61373 cat. 3			
Shock resistance	EN 61373 cat. 3			
Type test	EN 50155			
Housing material sensor	stainless steel			
Weight sensor (2 m cable)	650 g			
Electrical connection				
Cable	Cable halogen free and screened (specification on request), cable outlet straight			
Cable length	≤ 100 m			
Cable diameter	8.0 mm		8.2 mm	
Cable cross section	12 x 0.34 mm ²		6 x 1.0 mm ²	
Cable type	LK1076		LK1069	
Cable radius static / dynamic	24 mm / 41 mm			

(1) Output signal level depends on output current and temperature

(2) Please note the air gap table in this document.

Technical data

Signal pattern	X-	DI	VI	DL
Electrical data				
Supply voltage V_S (reverse polarity protected)	10 to 30 V DC	10 to 20 V DC		10 to 30 V DC
Current consumption per channel I_S (without load)	≤ 30 mA	–		< 12 mA
Output signal (short circuit proof)	square-wave signals			
Output signal high ⁽¹⁾	$\geq V_S - 1.0$ V	typ. 14 mA		$\geq V_S - 1.8$ V
Output signal level low ⁽¹⁾	≤ 1.0 V	typ. 7 mA		≤ 1.5 V
Output current per channel	≤ 20 mA	≤ 16 mA		≤ 10 mA
Input frequency target wheel	0 to 25 kHz			0.004 to 20 kHz
Output frequency	0 to 25 kHz			0.004 to 20 kHz
Duty (depends on measuring scale and air gap)	50% \pm 5%			50% \pm 10%
Phase shift	typ. 90°			
Slew rate (2 m cable)	≥ 10 V / μ s	≥ 6 V / μ s; $R_B = 560 \Omega$		≥ 4 V / μ s
Electromagnetic compatibility	rail vehicles(EN 50121-3-2) industrial applications (EN 61000-6-1 to 4)			
Insulation	500 V AC (EN 60439-1)			
Mechanical data				
Module m target wheel	1.00 / 1.25 / 1.50 / 1.75 / 2.00 / 2.25 / 2.50 / 3.50			
Permissible air gap (for module m) ⁽²⁾	0.2 to 3.0 mm			
Width of target wheel	≥ 10 mm (smaller ones on request)			
Form of target wheel	involute gear as per DIN 867, rectangular gear 1:1 or slotted disk (on request)			
Material of target wheel	ferromagnetic steel			
Operating and ambient temperature	-40 °C to +120 °C			
Storage temperature	-40 °C to +120 °C			
Protection class	IP 68			
Vibration resistance	EN 61373 cat. 3			
Shock resistance	EN 61373 cat. 3			
Type test	EN 50155			
Housing material sensor	stainless steel			
Weight sensor (2 m cable)	650 g			
Electrical connection				
Cable	Cable halogen free and screened (specification on request), cable outlet straight			
Cable length	≤ 100 m			
Cable diameter	8.2 mm	8.3 mm		8.0 mm
Cable cross section	6 x 1.0 mm ²	4 x 1.0 mm ²		12 x 0.34 mm ²
Cable type	LK1069	LK10741		LK1076
Cable radius static / dynamic	24 mm / 41 mm	25 mm / 42 mm		24 mm / 41 mm

(1) Output signal level depends on output current and temperature

(2) Please note the air gap table in this document.

Technical data

Signal pattern	HL	DM	VM
Electrical data			
Supply voltage V_S (reverse polarity protected)	10 to 30 V DC	10 to 20 V DC	
Current consumption per channel I_S (without load)	< 12 mA		
Output signal (short circuit proof)	square-wave signals		
Output signal high ⁽¹⁾	$\geq V_S - 1.8 V$		
Output signal level low ⁽¹⁾	$\leq 1.5 V$	$\leq 1.5 V^{(2)}$	
Output current per channel	$\leq 10 mA$	$\leq 15 mA$	
Input frequency target wheel	0.004 to 20 kHz	0.001 to 8 kHz	
Output frequency	0.004 to 20 kHz	0.001 to 8 kHz	
Duty (depends on measuring scale and air gap)	50% \pm 10%		
Phase shift	typ. 90°		
Slew rate (2 m cable)	$\geq 4 V / \mu s$		
Electromagnetic compatibility	rail vehicles(EN 50121-3-2) industrial applications (EN 61000-6-1 to 4)		
Insulation	500 V AC (EN 60439-1)		
Mechanical data			
Module m target wheel	1.00 / 1.25 / 1.50 / 1.75 / 2.00 / 2.25 / 2.50 / 3.50	2.00	
Permissible air gap (for module m) ⁽³⁾	0.2 to 3.0 mm		
Width of target wheel	$\geq 10 mm$ (smaller ones on request)		
Form of target wheel	involute gear as per DIN 867, rectangular gear 1:1 or slotted disk (on request)		
Material of target wheel	ferromagnetic steel		
Operating and ambient temperature	-40 °C to +120 °C	-40 °C to +85 °C	
Storage temperature	-40 °C to +120 °C		
Protection class	IP 68		
Vibration resistance	EN 61373 cat. 3		
Shock resistance	EN 61373 cat. 3		
Type test	EN 50155		
Housing material sensor	stainless steel		
Weight sensor (2 m cable)	650 g		
Electrical connection			
Cable	Cable halogen free and screened (specification on request), cable outlet straight		
Cable length	$\leq 100 m$		
Cable diameter	8.0 mm	6.3 mm	7.1 mm
Cable cross section	12 x 0.34 mm ²	2 x 3 x 0.5 mm ²	4 x 0.5 mm ²
Cable type	LK1076	LK1083/LK1084	LK1081
Cable radius static / dynamic	24 mm / 41 mm	19 mm / 32 mm	21 mm / 36 mm

(1) Output signal level depends on output current and temperature

(2) 7 V \pm 0.3 V at frequency < 1 Hz \pm 0.3 Hz

(3) Please note the air gap table in this document.

Signal pattern

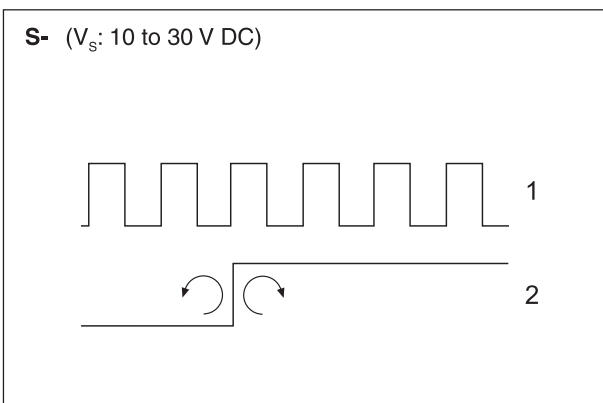
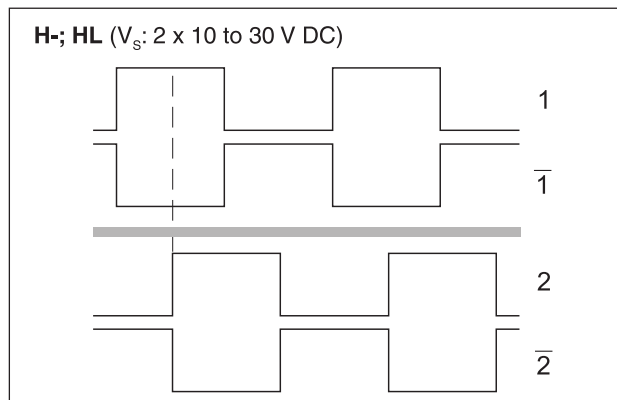
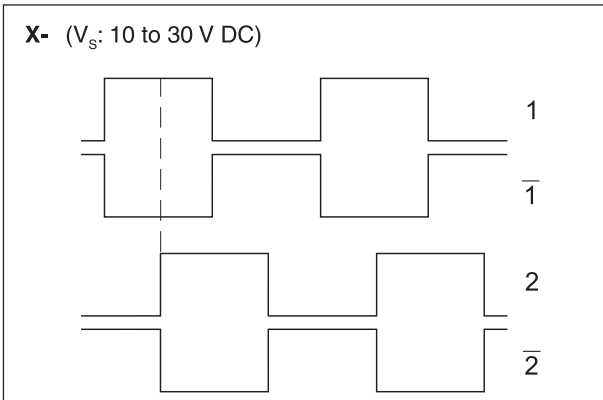
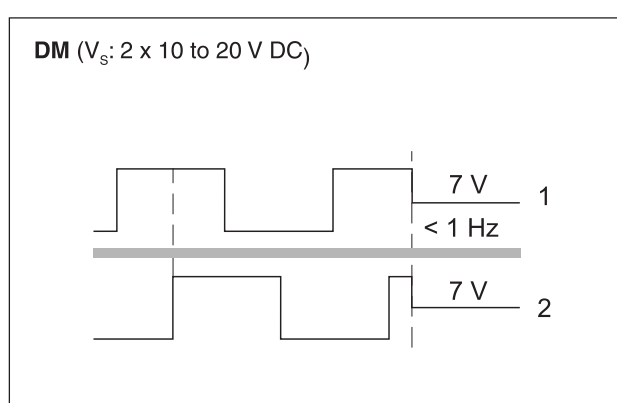
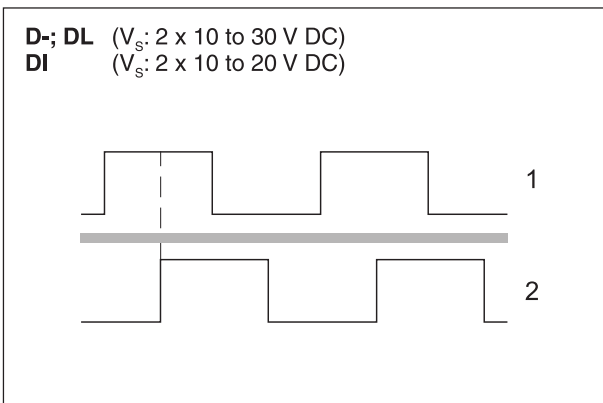
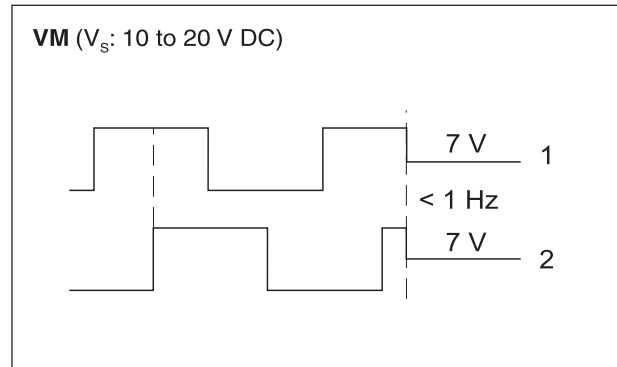
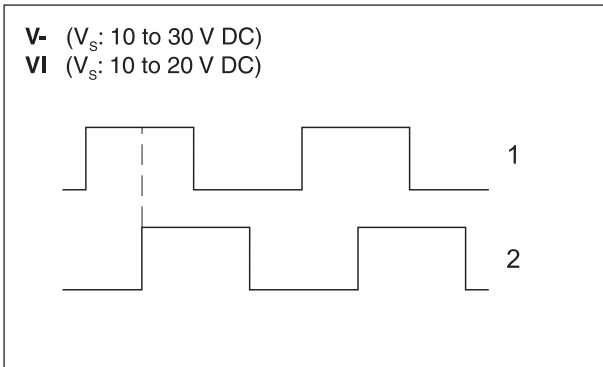

Explanation

- x- = voltage output
- xl = current output
- xL = voltage output (low current)⁽¹⁾
- xM = voltage output (standstill voltage)
- 1, 2 = channel 1, channel 2
- 1̄, 2̄ = inverse channel 1, inverse channel 2
- █ = galvanically isolated
- V_S = supply voltage

(1) with reduced current consumption

Signal level

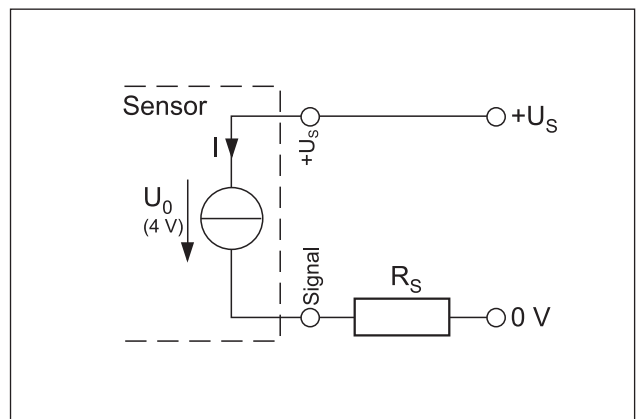
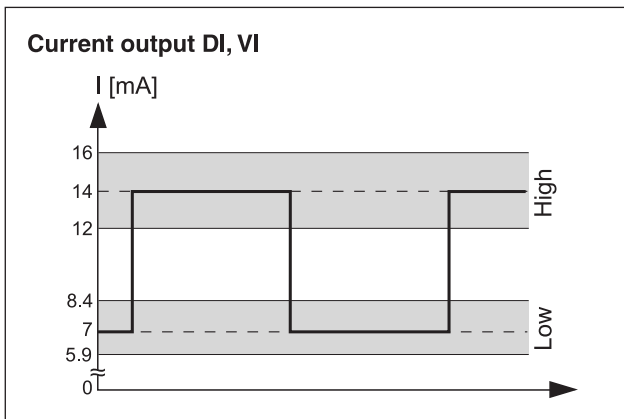
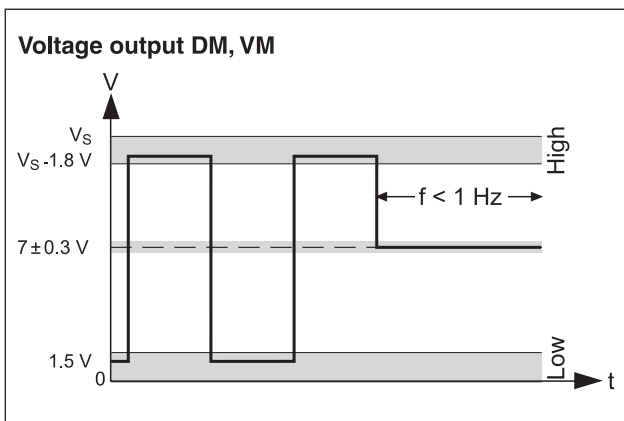
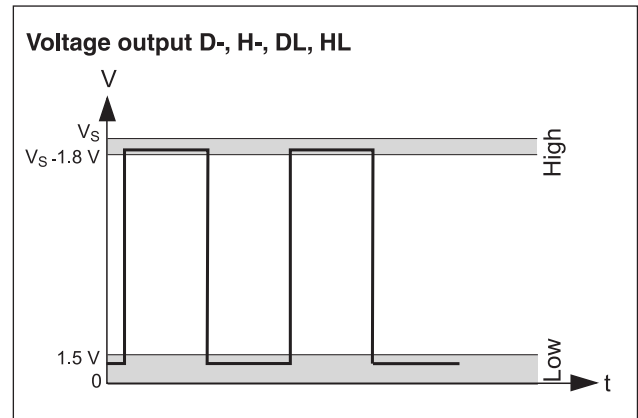
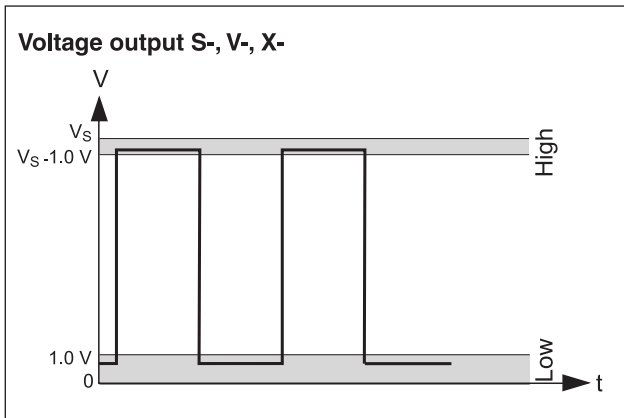

When using the current output, the resistor to be connected must not exceed a specific value:

$$R_{B,max} = (V_S - 4 \text{ V}) / I_{max}$$

with $V_S = 10 \text{ to } 20 \text{ V DC}$ and $I_{max} = 16 \text{ mA}$

Example for $V_S = 15 \text{ V}$:

$$R_{B,max} = 11 \text{ V} / 16 \text{ mA} = 690 \Omega$$

Electrical connection, Dimensions

Electrical connection

Signal	D-		H-		S-		V-		X-		DI		VI		DL		HL		DM		VM	
Channel 1	ye		ye		ye	ye	ye	ye	ye	ye	bl		bl	ye		ye		wh		bl		
Channel 2		wh		wh	wh	wh	wh	wh			gn	gn		wh		wh		gn	wh			
Channel 1̄			bk						bk							bk						
Channel 2̄				br					br							br						
GND (0 V)	bl	gr	bl	gr	bl	bl	bl	bl					bl	gr	bl	gr	bk	vi	gn			
+V _S (10 to 30 V DC)	rd	pi	rd	pi	rd	rd	rd	rd					rd	pi	rd	pi						
+V _S (10 to 20 V DC)									rd	ye	rd						rd	or	or			
Cable / Screen	1/1		1/1		1/1		1/1		1/1		1/1		1/1		1/1		2 / 2		1/1			

bk = black, bl = blue, br = brown, gn = green, gr = grey, or = orange, pi = pink, rd = red, vi = violet, ye = yellow, wh = white

Dimensions

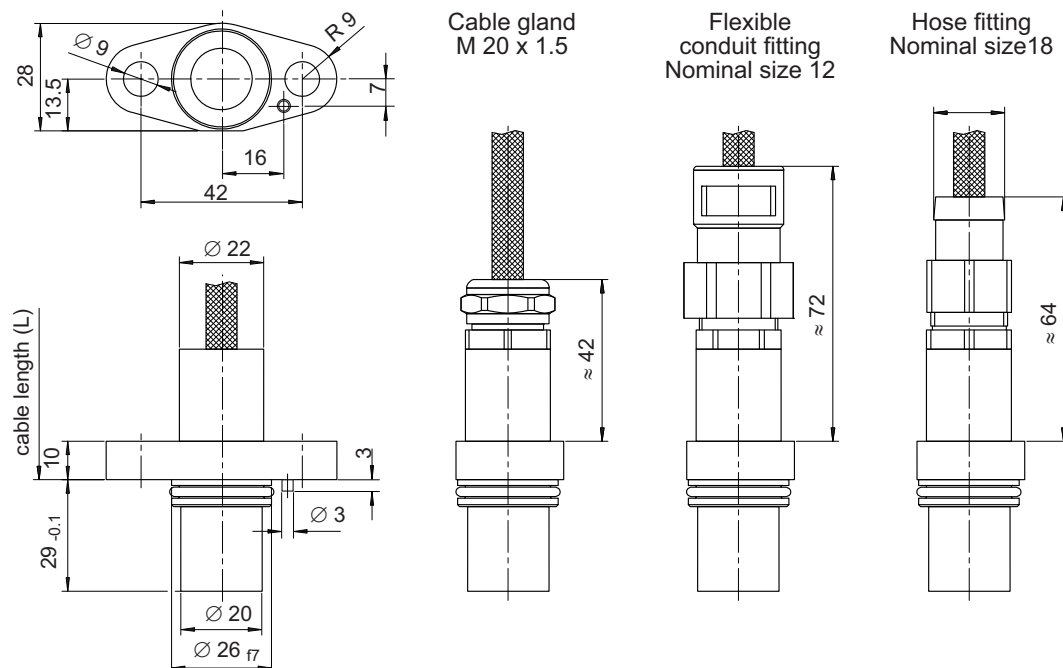

Assembly drawing

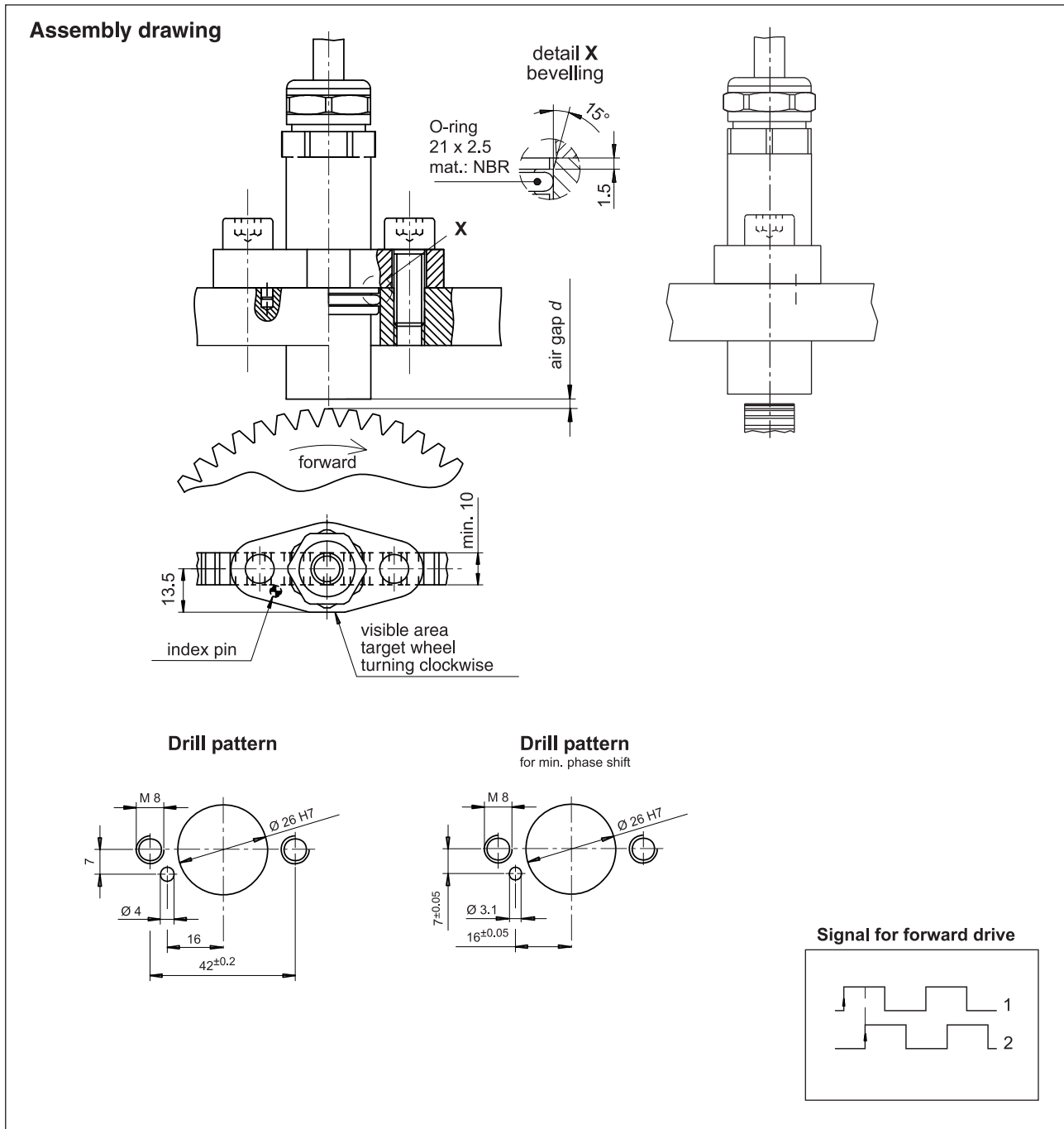

Please observe the EMC-reference into the operating instruction!

Permissible air gap (for module m)

	D-	H-	S-	V-	X-	DI	VI	DL	HL	DM	VM
m = 1.0				0.2 to 1.4 mm				0.2 to 0.9 mm			
m = 1.5				0.2 to 1.8 mm				0.2 to 1.5 mm			
m = 2.0				0.2 to 2.2 mm				0.2 to 2.0 mm		0.2 to 2.2 mm	
m = 2.5				0.2 to 2.8 mm				0.2 to 2.2 mm			
m = 3.5				0.2 to 3.0 mm				0.2 to 2.8 mm			

Type code GEL 2475

Signal pattern	
S	1-channel square-wave signals with direction signal
V	2-channel square-wave signals shifted by 90°
X	2-channel square-wave signals shifted by 90° and their inversed signals
D	2-channel square-wave signals shifted by 90°, galvanically isolated
H	2-channel square-wave signals shifted by 90° and their inversed signals, galvanically isolated
Signal output	
-	Voltage
I	Current (with signal patterns V and D only)
L	Voltage, with reduced current consumption (with signal patterns D and H only)
M	Standstill monitoring voltage 7 V (with signal patterns V and D only)
Module M	
100	Module 1.00
125	Module 1.25
150	Module 1.50
.	
.	
.	
350	Module 3.50
Cable screening	
L	Connected to sensor housing
P	Not connected to sensor housing
Cable outlet	
K	Cable gland
W	Flexible conduit fitting
G	Hose fitting
Cable length L	
xxx	Cable length in cm
Costumising	
N	Standard version
S	Special version
2475	

Notes: For a special customized version a Y-No. will be created. A special version 2475Yxxx is manufactured according to a drawing or application description and could differ from the technical standard specification.

Example for customized cable connections

Encoder end

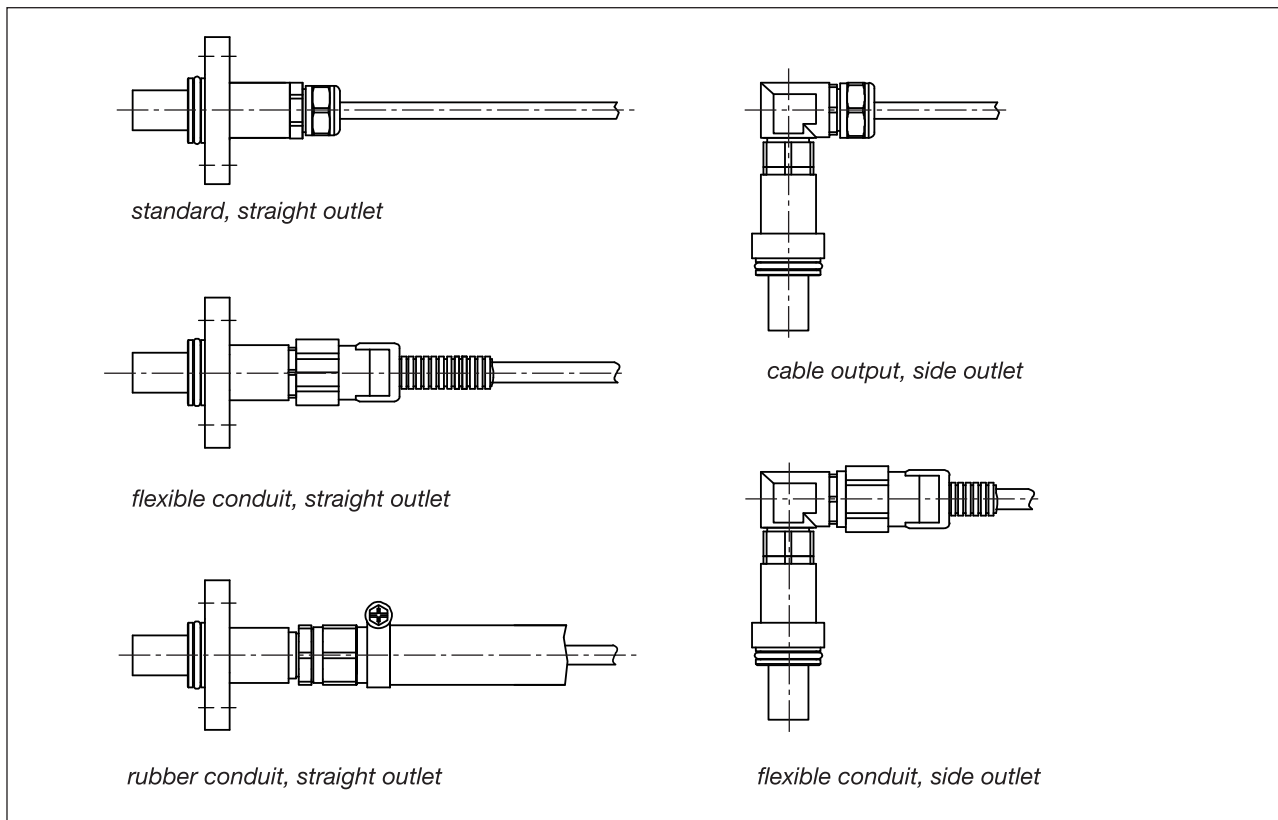

Cable end

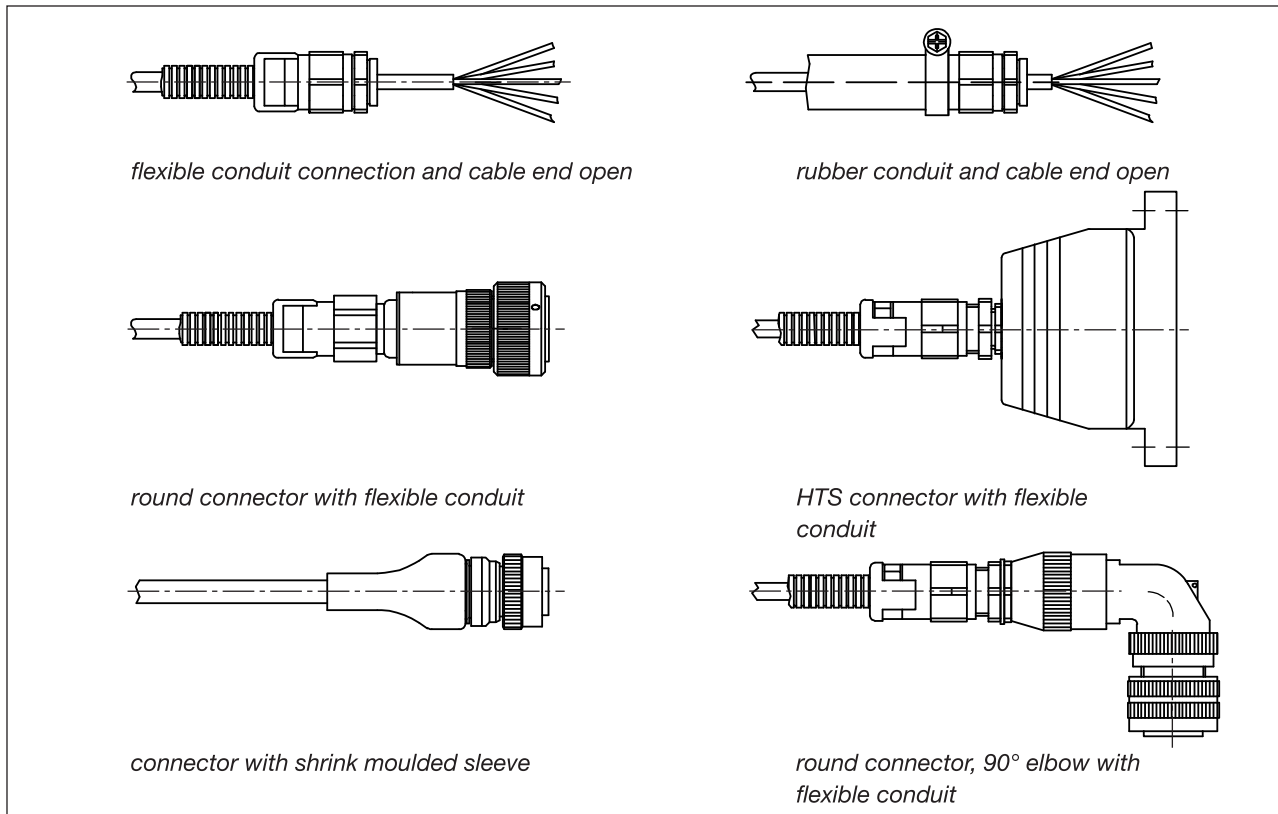

We have agencies in:

Austria

Belgium

Canada

China

Czech Republic

Denmark

Finland

France

Germany

Great Britain

Israel

Italy

Korea

Malaysia

Netherlands

Norway

Portugal

Sweden

Switzerland

Spain

Turkey

USA



... automates motion.

Lenord, Bauer & Co. GmbH
Dohlenstraße 32
46145 Oberhausen, GERMANY
Phone: +49 208 9963-0
Fax: +49 208 676292
Internet: www.lenord.de
E-Mail: info@lenord.de

Subject to technical modifications and typographical errors.
For the latest version please visit our web site : www.lenord.de .