

Magnetic absolute encoder

▶ GEL 2035

Serial interface (SSI), 24 Bit

SENSORLINE

▶ **LENORD+BAUER**

Technical information

Version 03.09



- ▶ Resolution: up to 24 Bit
- ▶ Precision: 0.8°
- ▶ Signal pattern: SSI and SSI with Resolver
- ▶ Singleturn (ST): Sampling using magneto-resistive (MR) sensor elements
- ▶ Multiturn (MT): Electronic gear with no additional mechanical components (contact-free, no mechanical gear, battery buffered)

Options for additional DC-isolated signal patterns

- ▶ Redundant resolver signal

General

The multiturn absolute encoder series GEL 2035 returns a unique positional value for every angular position via an SSI interface with up to 24 bit resolution, the singleturn and multiturn stages each operating with 12 bit resolution. The multiturn stage is based on an electronic gear that registers revolutions without any mechanical components. A battery buffer maintains operation of the encoder in the event of a power outage: even if the encoder shaft rotates while the power is off the absolute position will be correctly returned as soon as power is switched on. The combination with a resolver produces a highly compact redundant system. Complete DC-isolation of the resolver and the magnetic absolute encoder is realized.

General information

Construction

The absolute encoder GEL 2035 is based on a magnetic multiturn absolute encoder with electronic gear and returns a resolution of up to 24 bits. The absolute position is given via an SSI interface. If you wish to construct a completely redundant measuring system there is also the option of combining the magnetic multiturn with a resolver. In this combination you have an inductive resolver as singleturn absolute encoder with an analog output signal coupled with a magnetic multiturn absolute encoder with digital output. The encoder housing is of anodized aluminum with a standard flange of 58 mm. The SMD electronic components are implemented using the very latest technology. The absolute encoder GEL 2035 is suitable both for standard applications and for heavy-duty work, withstands aggressive media and has an impressively long maintenance-free life.

Measuring principle

The absolute encoder operates on the basis of contact-free magnetic sampling of a diametral magnet that is embedded in the encoder shaft. Magneto-resistive (MR) sensors register the orientation of the magnetic field directly as an absolute position within a single rotation and register the number of rotations independently of the power supply. Even without power (outages, maintenance) a battery buffer enables the GEL 2035 to detect and register changes of positions. This magnetic sampling technology is not subject to aging and is not affected by temperature fluctuations, dirt or condensation.

Type of code / Interface

The magnetic absolute encoder returns the positional values in Gray code via an SSI interface. The redundant resolver signals are provided in the form of analog voltages.

Features

The maximum transfer rate depends on the cable length. We recommend shielded twisted-pair cable.

Principle of serial data transmission (SSI)

Gray code (25 Bit), RS 422 / RS 485 standard

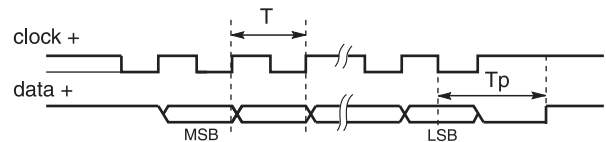

$f \geq 40 \text{ kHz}$

$T_p = \text{Interval between two pulses} \geq 25 \mu\text{s}$

$T = \text{Duration of the clock signal}$

- ▶ Up to 24 bit resolution
- ▶ Resolver with Sin/Cos output signal returns redundant positional signal within one revolution
- ▶ Special battery-protection mode activated for storage by pressing the preset button when $V_S = 0 \text{ V}$. Switches automatically to normal mode after starting up.
- ▶ Lithium ion battery with a lifetime of up to ten years
- ▶ Changes of positions are registered even without power supply (system runs down during a power outage, shaft movement during maintenance).
- ▶ Battery buffer serves for emergency operation during power outages and maintenance work. Without power supply the maximum operating speed of 6000 min^{-1} is allowed shortly.

Technical data

General	
Accuracy (DIN 32876)	0.8° (> 9 Bit)
Electrical data	
Operating voltage	10 to 30 V DC with reverse battery protection
Power consumption	< 0.3 W, load-free output (SSI base encoder)
Resolution Singleturn (ST)	12 bit (4096 measuring interval in 360°)
Resolution Multiturn (MT)	12 bit (4096 revolution, electronic gear with battery buffer)
Transmission frequency (SSI)	40 kHz to 500 kHz
Output code	Gray
Transmission	max. 1200 m depending on the transfer rate
The immunity of interference	highly immune to interference due to symmetrical data transfer
Initialization (application V_S)	1 s (switchover time from sleep mode with battery-protection to operating mode)
Position evaluation	45 μ s
Output time	20 μ s
Mechanical data	
Housing diameter	58 mm
Flange	Clamping flange
Shaft dimensions (D x length) [mm]	10 x 20
Housing length	53 mm (SSI), 63 mm (SSI with resolver)
Weight	300 g (SSI), 450 g (SSI with resolver)
Material	anodized aluminum
Operating speed (limit)	6,000 min^{-1}
Shaft loading (axial / radial)	Distance contact point: 5 mm, at 1,000 min^{-1} = 160 N / 80 N, at 6,000 min^{-1} = 100 N / 80 N
Bearing life	> 10^9 at 1,000 min^{-1}
Operating torque	< 3 Ncm
Environmental data	
Protection class	IP 67
Shock resistance (IEC 68, 2-27)	2,000 m/s^2 , 11 ms
Vibration resistance (IEC 68, 2-6)	200 m/s^2 , 10 to 2,000 Hz
Working temperature range	-40 °C to 85 °C
Operating temperature range	-40 °C to 85 °C
Storage temperature range	-40 °C to 85 °C
Relative humidity max.	100 %
Condensation permissible	yes
EMC	EN 61000-6-1 to 4
Insulation strength	Ri > 1 M Ω at 500 V AC

Dimensioned drawing GEL 2035 (SSI)

Dimension GEL 2035 (SSI)

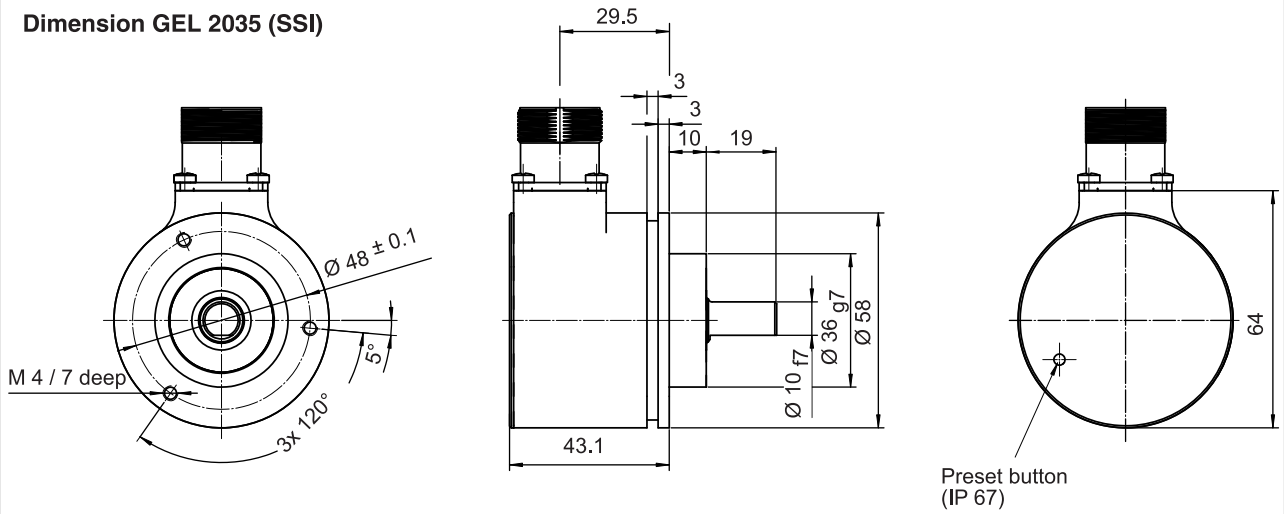

12-pole connector pin layout M23

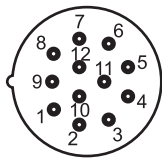

SSI Signal	
PIN	Function
1	GND
2	DATA +
3	Clock +
8	$V_S = 24\text{ V DC}$
9	Reset (GND, $t > 100\text{ ms}$)
10	Data -
11	Clock -

Dimensioned drawing GEL 2035 (SSI with resolver)

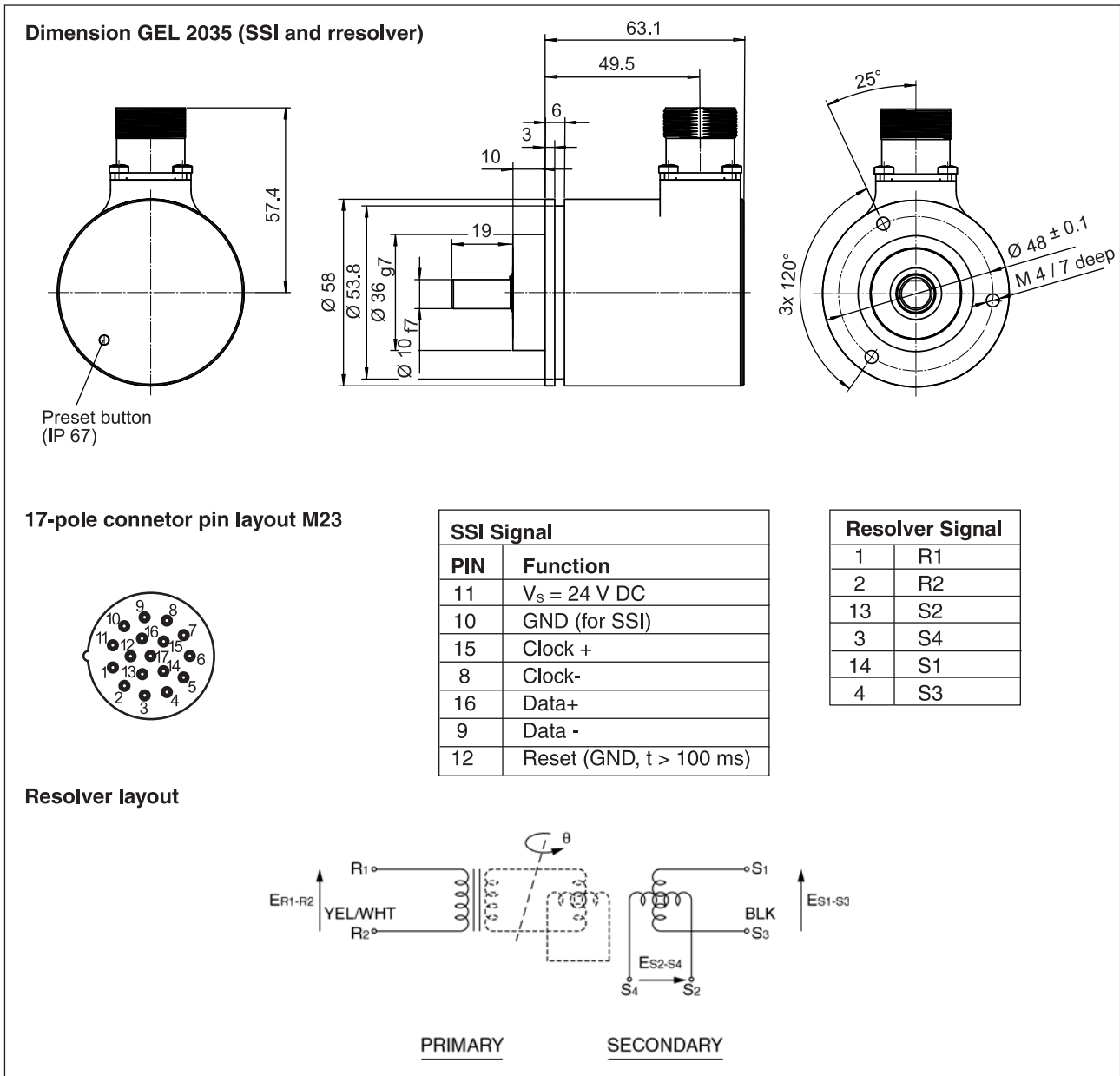

Technical data resolver

Input voltage	7 V rms
Primary	$E_{R1-R2} = E \sin \omega t$
Secondary	$E_{S1-S3} = K E_{R1-R2} \cos \Theta$, $K = \text{conversion ratio}$ $E_{S2-S4} = K E_{R1-R2} \sin \Theta$
Input frequency	10 kHz (max. permissible deviation $\pm 5 \%$)
Conversion ratio	$0.5 \pm 5 \%$
Precision (measurement errors)	$\pm 10'$
Zero potential	max. 20 mV rms
Phase separation	Nominally 0°
Speed ripple	max. 1.5 % at $1,500 \text{ min}^{-1}$
Insulation resistance	100 M Ω at 500 V DC
Input current	max. 80 mA

Available variants

PRESET-Function at SSI

At any given rotary position the output signals can be set to preset values. As default the singleturn is set to 2^{n-1} and the multiturn is set to half of its maximum value. The preset can be set electrically by applying V_s to the Preset line for $t > 100$ ms (do not apply permanently). Alternatively, a preset pushbutton is optionally available, recessed in the encoder base (IP 67). This is to be pushed with a blunt pin for $t > 100$ ms. After enabling the PRESET function the value is directly available, but it will first be transmitted via SSI after 3 s.

Available variants

Type code	Flange	Absolute encoder variants
GEL2035SDG1212BES40	clamping flange	GEL 2035 (24 Bit SSI)
GEL2035SRG1212BES40	clamping flange	GEL 2035 (24 Bit SSI with resolver)

Customer-specific variants

Customer-specific modifications to mechanical and electrical properties are fundamentally possible.

Accessories

For further information about the accessories, please refer to our technical information encoder accessories.

Your notes:

We have agencies in:

Austria
Belgium
Canada
China
Czech Republic
Denmark
Finland
France
Germany
Great Britain
Israel
Italy
Korea
Malaysia
Netherlands
Norway
Portugal
Sweden
Switzerland
Spain
Turkey
USA



... automates motion.

Lenord, Bauer & Co. GmbH
Dohlenstraße 32
46145 Oberhausen, Deutschland
Phone: +49 208 9963-0
Fax: +49 208 676292
Internet: www.lenord.de
E-Mail: info@lenord.de

Subject to technical modifications and typographical errors.
For the latest version please visit our web site : www.lenord.de .